

GRAND

STRUCTURAL - STRAIGHT FLUTED ALUMINUM POLE

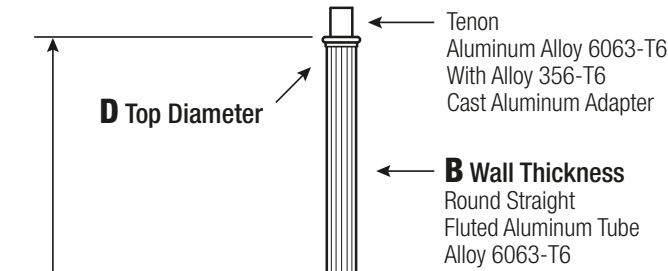

FHWA Accepted Breakaway Options Available

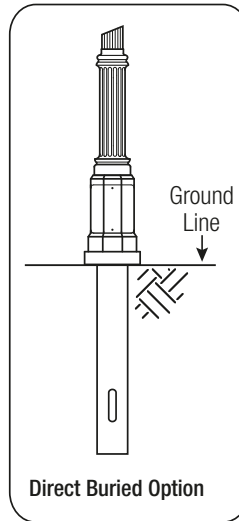

Base

Cast Aluminum, 1-Piece Structural Pedestal Base of Alloy 356 per ASTM B26 or B108. The base shall have an access door with cast aluminum cover and stainless steel attaching hardware. An internal grounding provision will be provided opposite the access door.

Pole

The pole shaft will be constructed of seamless extruded tube of 6063 Aluminum Alloy per the requirements of ASTM B221. The shaft shall be joined to the structural base by means of a complete circumferential weld in accordance with AWS Specification D1.2. The assembly shall be full-length heat-treated after weld to produce a T6 temper.

Anchorage

Anchorage Kit will include four (4) L-shaped Steel Anchor Bolts conforming to AASHTO M314-90 Grade 55. Ten inches (10") of threaded end will be galvanized per ASTM A153. Kits will contain four (4) Hex Nuts, four (4) Lock Washers, and four (4) Flat Washers (all components Galvanized Steel). A bolt circle template will be provided.

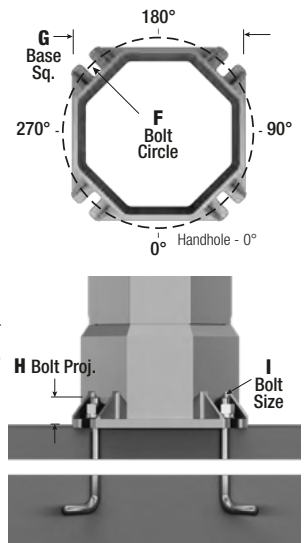

NOTE: All GRAND pole options may be specified in designs utilizing Direct Buried anchorage.

Vibration Damper

When determined necessary by Hapco, a Vibration Damper will be factory installed inside the pole shaft. Customer specification of the damper is available.

Powder Coated Finish per Customer Specification.

C BUTT DIA.	D TOP DIA.	F BOLT CIR. DIA.	G BASE SQ.	H BOLT PROJ.	I BOLT SIZE
4	4	11.375 - 12.375	11.5	2	.5 x 17 x 3
5	5	11.375 - 12.375	11.5	2	.5 x 17 x 3

■ Square Bolt Pattern

Dimensions in Inches



WARNING: Do not install light pole without luminaire.

GRAND

STRUCTURAL STRAIGHT FLUTED ALUMINUM POLE

A MTG. HGT.	B WALL THICKNESS	C BUTT DIA.	TOTAL LUM. WEIGHT	MAXIMUM EPA						CATALOG NUMBER*
				90	100	110	120	130	140	
8	0.125	4	100	16.9	13.5	11.1	9.2	7.8	6.6	GRS08B4-4-SF12-**
	0.188	4	100	17.6	14.2	11.6	9.7	8.2	7.0	GRS08D4-4-SF12-**
	0.125	5	100	20.6	16.6	13.6	11.4	9.6	8.2	GRS08B5-4-SF12-**
10	0.125	4	100	13.1	10.4	8.5	7.0	5.9	4.9	GRS10B4-4-SF12-**
	0.188	4	100	13.7	10.9	8.8	7.3	6.1	5.2	GRS10D4-4-SF12-**
	0.125	5	100	16.0	12.8	10.4	8.6	7.2	6.0	GRS10B5-4-SF12-**
12	0.125	4	100	10.2	8.0	6.4	5.2	4.3	3.5	GRS12B4-4-SF12-**
	0.188	4	100	10.9	8.6	6.9	5.6	4.6	3.8	GRS12D4-4-SF12-**
	0.125	5	100	12.7	10.0	8.0	6.5	5.4	4.5	GRS12B5-4-SF12-**
14	0.125	4	95	7.9	6.1	4.8	3.8	3.0	2.4	GRS14B4-4-SF12-**
	0.188	4	100	8.6	6.7	5.2	4.2	3.3	2.6	GRS14D4-4-SF12-**
	0.125	5	100	10.0	7.8	6.0	4.8	3.9	3.2	GRS14B5-4-SF12-**
16	0.125	4	60	6.2	4.7	3.5	2.7	2.0	1.5	GRS16B4-4-SF12-**
	0.188	4	40	6.8	5.2	4.0	3.0	2.3	1.7	GRS16D4-4-SF12-**
	0.125	5	40	7.8	6.0	4.5	3.4	2.7	2.1	GRS16B5-4-SF12-**
18	0.125	4	45	4.8	3.5	2.5	1.7	1.2	-	GRS18B4-4-SF12-**
	0.188	4	55	5.4	3.9	2.8	2.0	1.4	-	GRS18D4-4-SF12-**
	0.125	5	45	6.2	4.6	3.2	2.3	1.6	1.2	GRS18B5-4-SF12-**
20	0.125	4	55	3.4	2.3	1.5	-	-	-	GRS20B4-4-SF12-**
	0.188	4	45	4.2	2.8	2.0	1.2	-	-	GRS20D4-4-SF12-**
	0.125	5	50	4.6	3.3	2.1	1.3	-	-	GRS20B5-4-SF12-**
25	0.188	5	40	4.6	3.3	2.1	1.3	0.8	-	GRS20D5-4-SF12-**
	0.125	4	40	1.0	-	-	-	-	-	GRS25B4-4-SF12-**
	0.188	4	70	1.8	-	-	-	-	-	GRS25D4-4-SF12-**
0.188	5	40	1.8	0.8	-	-	-	-	GRS25D5-4-SF12-**	

EPA Notes: Effective Projected Area (EPA) in square feet. EPA's calculated using wind velocity (mph) indicated in accordance with 2015 AASHTO LRFD (7th Edition) using a 50-year design life. Maximum EPA is based on the luminaire weight shown. Increased luminaire weight may reduce maximum EPA. If weight is exceeded, or if other design life or code is required, please consult the factory.

*4-Bolt Base Anchorage shown. For direct buried design replace -4 in catalog number with -E.

Catalog Number System

The catalog number for Hapco poles utilizes the following identification system.



Catalog Number Example -

GRS 14 D 4 - 4 - SF12 - BA

GRAND Structural Base, 14' Mounting Height, .188" Wall Thickness, 4" Butt Diameter, 4-Bolt Base, Straight Fluted Shaft - 12 Flute, Black Powder Coat Finish

Wall Thickness B = .125" D = .188"
Butt Dia. 4 = 4" 5 = 5"
Anchorage 4 = 4-Bolt Base E = Direct Buried

Shaft Style SF12 = Straight Fluted - 12-Flute

Powder Coat Finish
 BA - Black Powder Coat BV - Dark Green Powder Coat
 BH - White Powder Coat GC - Gray Powder Coat
 BM - Dark Bronze Powder Coat SC - Special Colors*
* Provide RAL # or Sample Color Chip

Mounting Options

Tenon Mount
 For Tenon Mount applications specify both Tenon diameter and length.



Flute Options



CATALOG NUMBER:	QUANTITY:
CUSTOMER NAME:	
PROJECT:	LOCATION:
NOTES:	