

REDDING

CLAMSHELL - TAPERED FLUTED ALUMINUM POLE

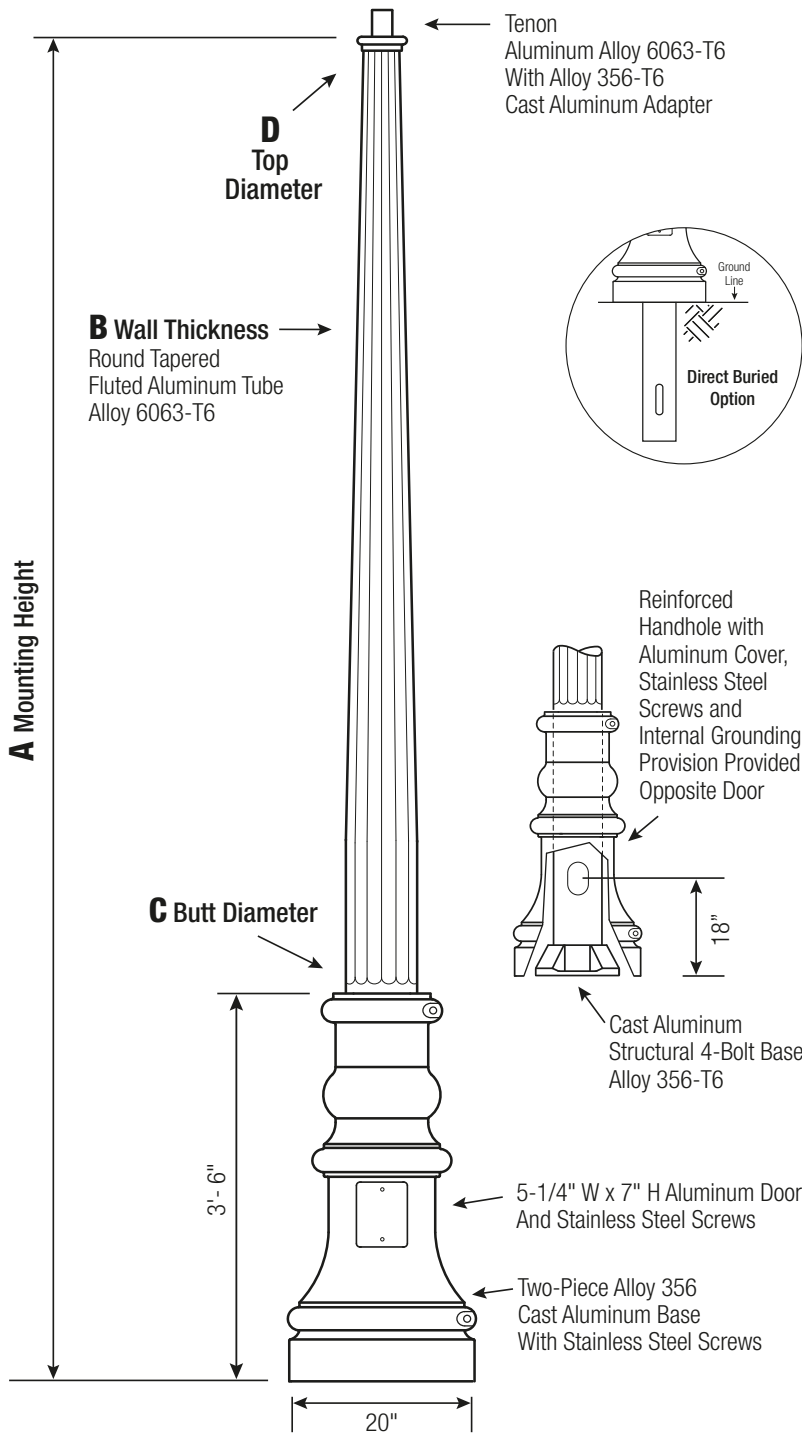

Powder Coated Finish per Customer Specification.

C BUTT DIA.	D TOP DIA.	F BOLT CIR. DIA.	G BASE DIA.	H BOLT PROJ.	I BOLT SIZE
6 (Up To .188")	Varies	9 - 10	9.75	2.75	.75 x 30 x 3
6 (.250" +)	Varies	9 - 10	9.75	2.75	1 x 36 x 4
7	Varies	10 - 11	10.5	2.75	1 x 36 x 4
8	Varies	11 - 12	11.25	2.75	1 x 36 x 4
9	Varies	12.5 - 14	12.75	2.75	1 x 36 x 4

Dimensions in Inches

Clamshell Base

Cast Aluminum, 2-Piece Decorative Base of Alloy 356 per ASTM B26 or B108 with stainless steel attaching hardware.

Pole

The pole shaft will be constructed of seamless extruded tube of 6063 Aluminum Alloy per the requirements of ASTM B221. The 4-Bolt Cast Aluminum Base Flange will be of Alloy 356-T6. The pole shaft shall be joined to the base by means of a complete circumferential weld in accordance with AWS Specification D1.2. The shaft assembly shall be full-length heat treated after base weld to produce a T6 temper.

Anchorage

Anchorage Kit will include four (4) L-shaped Steel Anchor Bolts conforming to AASHTO M314-90 Grade 55. Ten inches (10") of threaded end will be galvanized per ASTM A153. Kits will contain four (4) Hex Nuts, four (4) Lock Washers, and four (4) Flat Washers (all components Galvanized Steel). A bolt circle template will be provided

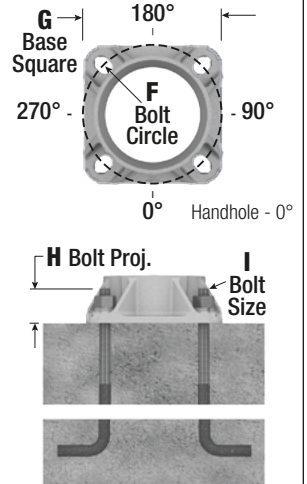

NOTE: REDDING pole options may be specified in designs utilizing Direct Buried anchorage.

Handhole

6" Butt Diameter - Reinforced, 3" x 5" curved Cast Aluminum Frame (Alloy 356-T6) with Aluminum Door and two (2) SS Hex Head Screws. A Grounding Provision incorporating a 3/8" diameter hole is provided opposite the Handhole.

7"+ Butt Diameters - Reinforced, 4" x 6" curved Cast Aluminum Frame (Alloy 356-T6) with Aluminum Door and two (2) SS Hex Head Screws. Reinforced Frame will contain a tapped 3/8"-16NC Grounding Provision.

Vibration Damper

When determined necessary by Hapco, a Vibration Damper will be factory-installed inside the pole shaft. Customer specification of the damper is available.



WARNING: Do not install light pole without luminaire.

