

# REDDING

## CLAMSHELL - STRAIGHT ROUND ALUMINUM POLE

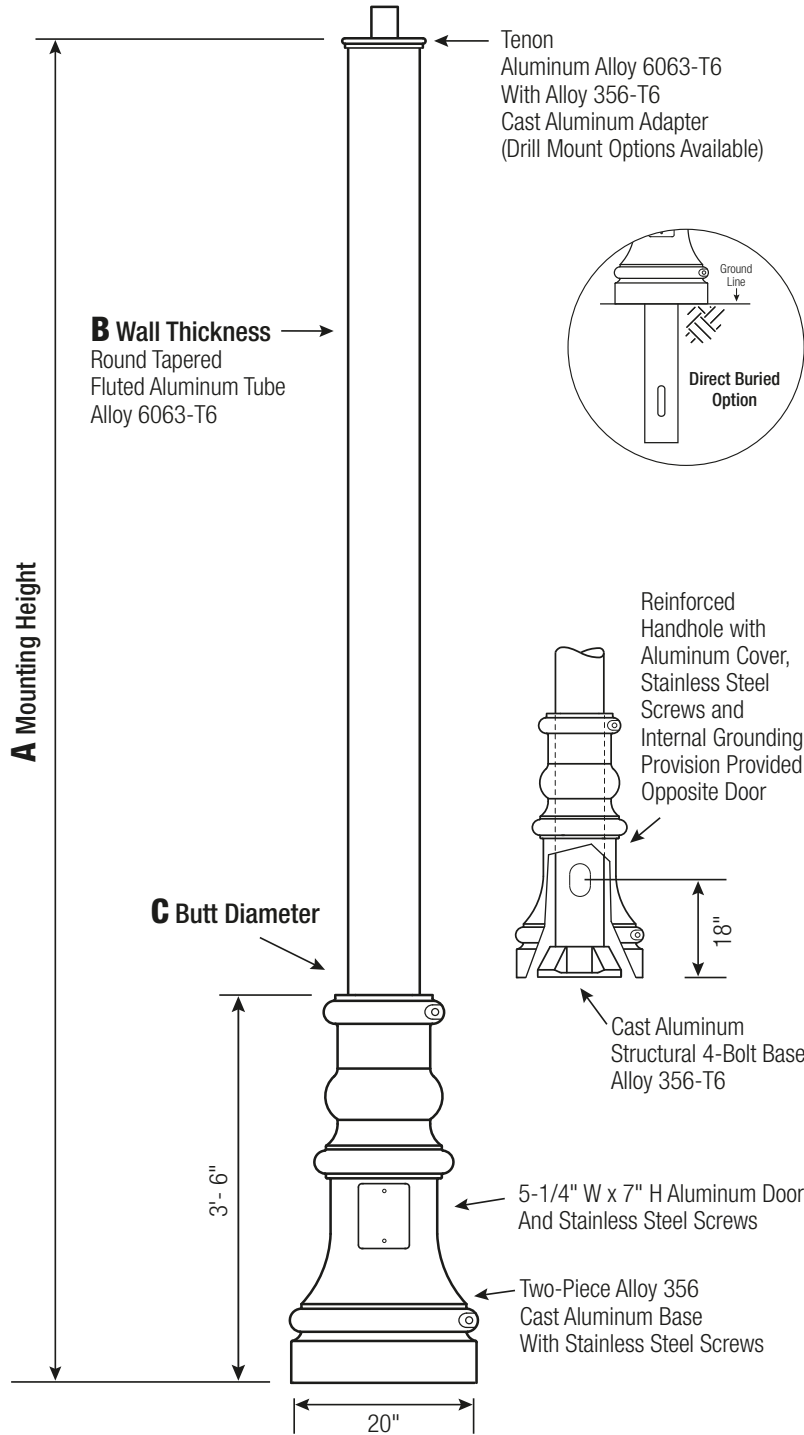

Powder Coated Finish per Customer Specification.

C BUTT DIA.	D TOP DIA.	F BOLT CIR. DIA.	G BASE DIA.	H BOLT PROJ.	I BOLT SIZE
6 (Up To .188")	6	9 - 10	9.75	2.75	.75 x 30 x 3
6 (.250" +)	6	9 - 10	9.75	2.75	1 x 36 x 4
7	7	10 - 11	10.5	2.75	1 x 36 x 4
8	8	11 - 12	11.25	2.75	1 x 36 x 4
9	9	12.5 - 14	12.75	2.75	1 x 36 x 4

Dimensions in Inches

### Clamshell Base

Cast Aluminum, 2-Piece Decorative Base of Alloy 356 per ASTM B26 or B108 with stainless steel attaching hardware.

### Pole

The pole shaft will be constructed of seamless extruded tube of 6063 Aluminum Alloy per the requirements of ASTM B221. The 4-Bolt Cast Aluminum Base Flange will be of Alloy 356-T6. The pole shaft shall be joined to the base by means of a complete circumferential weld in accordance with AWS Specification D1.2. The shaft assembly shall be full-length heat treated after base weld to produce a T6 temper.

### Anchorage

Anchorage Kit will include four (4) L-shaped Steel Anchor Bolts conforming to AASHTO M314-90 Grade 55. Ten inches (10") of threaded end will be galvanized per ASTM A153. Kits will contain four (4) Hex Nuts, four (4) Lock Washers, and four (4) Flat Washers (all components Galvanized Steel). A bolt circle template will be provided

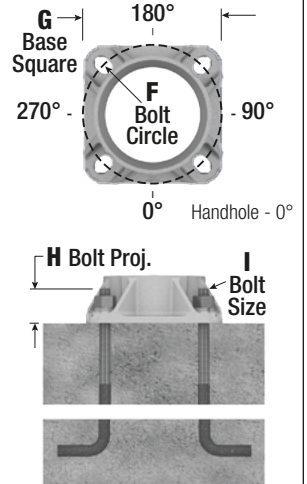

**NOTE:** All REDDING pole options may be specified in designs utilizing Direct Buried anchorage.

### Handhole

6" Butt Diameter - Reinforced, 3" x 5" curved Cast Aluminum Frame (Alloy 356-T6) with Aluminum Door and two (2) SS Hex Head Screws. A Grounding Provision incorporating a 3/8" diameter hole is provided opposite the Handhole.

7"+ Butt Diameters - Reinforced, 4" x 6" curved Cast Aluminum Frame (Alloy 356-T6) with Aluminum Door and two (2) SS Hex Head Screws. Reinforced Frame will contain a tapped 3/8"-16NC Grounding Provision.

### Vibration Damper

When determined necessary by Hapco, a Vibration Damper will be factory-installed inside the pole shaft. Customer specification of the damper is available.



**WARNING:** Do not install light pole without luminaire.

# REDDING

## CLAMSHELL STRAIGHT ROUND ALUMINUM POLE

A MTG. HGT.	B WALL THICKNESS	C BUTT DIA.	TOTAL LUM. WEIGHT	MAXIMUM EPA						CATALOG NUMBER*
				90	100	110	120	130	140	
12	0.125	6	100	23.7	19.0	14.9	12.3	10.4	8.8	RDC12B6-4-SR-**-
	0.188	6	100	36.1	29.1	23.2	19.4	16.4	14.0	RDC12D6-4-SR-**-
14	0.125	6	100	19.2	15.4	11.7	9.7	8.1	6.8	RDC14B6-4-SR-**-
	0.188	6	100	29.8	24	18.8	15.7	13.2	11.2	RDC14D6-4-SR-**-
16	0.125	6	100	15.7	12.5	9.2	7.5	6.2	5.2	RDC16B6-4-SR-**-
	0.188	6	100	25.0	20.0	15.4	12.7	10.7	9.1	RDC16D6-4-SR-**-
18	0.125	6	100	12.5	9.9	6.9	5.6	4.6	3.8	RDC18B6-4-SR-**-
	0.188	6	100	20.5	16.3	12.3	10.1	8.4	7.1	RDC18D6-4-SR-**-
20	0.125	6	100	9.9	7.7	5.0	4.0	3.2	2.6	RDC20B6-4-SR-**-
	0.188	6	100	16.8	13.4	9.7	7.9	6.5	5.5	RDC20D6-4-SR-**-
	0.250	6	100	23.3	18.6	14.0	11.5	9.6	8.1	RDC20F6-4-SR-**-
	0.125	7	100	16.0	12.7	9.2	7.5	6.2	5.2	RDC20B7-4-SR-**-
	0.188	7	100	25.8	20.6	15.8	13.0	10.9	9.2	RDC20D7-4-SR-**-
	0.250	7	100	34.9	28.0	21.8	18.1	15.2	13.0	RDC20F7-4-SR-**-
	0.188	8	100	36.0	28.9	22.7	18.8	15.9	13.5	RDC20D8-4-SR-**-
	0.250	8	100	48.3	38.9	30.9	25.7	21.7	18.6	RDC20F8-4-SR-**-
25	0.125	6	45	5.5	4.1	1.8	1.2	0.8	-	RDC25B6-4-SR-**-
	0.188	6	95	10.1	7.9	4.8	3.8	3.0	2.4	RDC25D6-4-SR-**-
	0.250	6	100	14.8	11.7	8.0	6.4	5.2	4.3	RDC25F6-4-SR-**-
	0.125	7	95	9.7	7.6	4.7	3.7	2.9	2.3	RDC25B7-4-SR-**-
	0.188	7	100	17.0	13.5	9.6	7.7	6.4	5.3	RDC25D7-4-SR-**-
	0.250	7	100	23.8	19.0	14.1	11.6	9.6	8.1	RDC25F7-4-SR-**-
	0.312	7	100	30.3	24.2	18.4	15.2	12.7	10.8	RDC25G7-4-SR-**-
	0.188	8	100	25.0	19.9	15.0	12.3	10.2	8.6	RDC25D8-4-SR-**-
	0.250	8	100	34.2	27.4	21.1	17.5	14.7	12.5	RDC25F8-4-SR-**-
	0.312	8	100	42.9	34.5	27.0	22.4	18.9	16.1	RDC25G8-4-SR-**-
	0.188	9	100	33.9	27.1	21.0	17.3	14.5	12.0	RDC25D9-4-SR-**-
	0.250	9	100	45.8	36.8	29.0	24.1	20.3	16.9	RDC25F9-4-SR-**-
30	0.125	6	75	1.6	0.9	-	-	-	-	RDC30B6-4-SR-**-
	0.188	6	50	5.9	4.3	1.6	1.1	0.6	-	RDC30D6-4-SR-**-
	0.250	6	75	9.2	7.1	3.9	2.9	2.2	1.7	RDC30F6-4-SR-**-
	0.125	7	50	5.7	4.3	1.7	1.1	0.7	-	RDC30B7-4-SR-**-
	0.188	7	100	10.9	8.5	5.1	4.0	3.1	2.5	RDC30D7-4-SR-**-
	0.250	7	100	16.2	12.8	8.7	7.0	5.7	4.6	RDC30F7-4-SR-**-
	0.312	7	100	21.3	16.8	12.0	9.8	8.1	6.7	RDC30G7-4-SR-**-
	0.188	8	100	17.4	13.7	9.5	7.7	6.3	5.2	RDC30D8-4-SR-**-
	0.250	8	100	24.6	19.6	14.4	11.8	9.8	8.2	RDC30F8-4-SR-**-
	0.312	8	100	31.5	25.2	19.0	15.6	13.1	11.0	RDC30G8-4-SR-**-
	0.188	9	100	24.6	19.6	14.5	11.8	9.8	7.8	RDC30D9-4-SR-**-
	0.250	9	100	34.1	27.2	20.8	17.1	14.3	11.7	RDC30F9-4-SR-**-
35	0.188	6	75	1.8	1.0	-	-	-	-	RDC35D6-4-SR-**-
	0.250	6	55	4.9	3.5	0.7	-	-	-	RDC35F6-4-SR-**-
	0.125	7	75	2.0	1.2	-	-	-	-	RDC35B7-4-SR-**-
	0.188	7	40	7.0	5.2	2.2	1.4	1.0	0.6	RDC35D7-4-SR-**-
	0.250	7	85	10.7	8.2	4.6	3.5	2.7	2.1	RDC35F7-4-SR-**-
	0.312	7	100	14.5	11.3	7.2	5.6	4.5	3.6	RDC35G7-4-SR-**-
	0.188	8	100	11.7	9.1	5.4	4.2	3.3	2.5	RDC35D8-4-SR-**-
	0.250	8	100	17.6	13.8	9.3	7.5	6.1	5.0	RDC35F8-4-SR-**-
	0.312	8	100	23.1	18.3	13.1	10.6	8.7	7.3	RDC35G8-4-SR-**-
	0.188	9	100	17.8	14.0	9.6	7.7	6.2	4.6	RDC35D9-4-SR-**-
0.250	9	100	25.5	20.2	14.7	12.0	9.9	7.8	RDC35F9-4-SR-**-	
40	0.250	6	60	1.2	-	-	-	-	-	RDC40F6-4-SR-**-
	0.188	7	80	2.7	1.8	-	-	-	-	RDC40D7-4-SR-**-
	0.250	7	40	6.7	5.0	1.6	1.0	-	-	RDC40F7-4-SR-**-
	0.312	7	60	9.7	7.3	3.6	2.6	1.8	1.3	RDC40G7-4-SR-**-
	0.188	8	45	7.9	5.9	2.5	1.7	1.1	0.7	RDC40D8-4-SR-**-
	0.250	8	95	12.1	9.3	5.3	4.0	3.1	2.4	RDC40F8-4-SR-**-
	0.312	8	100	16.6	12.9	8.3	6.6	5.2	4.2	RDC40G8-4-SR-**-
	0.188	9	85	12.6	9.8	5.8	4.5	3.4	2.1	RDC40D9-4-SR-**-
	0.250	9	100	18.8	14.8	9.9	7.9	6.4	4.6	RDC40F9-4-SR-**-

**EPA Notes:** Effective Projected Area (EPA) in square feet. EPA's calculated using wind velocity (mph) indicated in accordance with 2015 AASHTO LRFD (7th Edition) using a 50-year design life. Maximum EPA is based on the luminaire weight shown. Increased luminaire weight may reduce maximum EPA. If weight is exceeded, or if other design life or code is required, please consult the factory.

\*4-Bolt Base Anchorage shown. For direct buried design replace -4 in catalog number with -E.

### Catalog Number System

The catalog number for Hapco poles utilizes the following identification system.

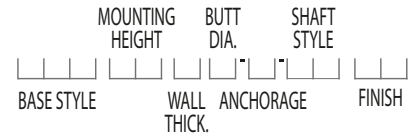

### Catalog Number Example -

**RDC 40 G 8 - 4 - SR - BA**

REDDING Clamshell Base, 40' Mounting Height, .312" Wall Thickness, 8" Butt Diameter, 4-Bolt Base, Straight Round Shaft, Black Powder Coat Finish

### Wall Thickness

B = .125"  
D = .188"  
F = .250"  
G = .312"

### Butt Dia.

6 = 6"  
7 = 7"  
8 = 8"  
9 = 9"

### Anchorage

4 = 4-Bolt Base  
E = Direct Buried

### Shaft Style

SR = Straight Round

### Powder Coat Finish

BA - Black Powder Coat

BH - White Powder Coat

BM - Dark Bronze Powder Coat

BV - Dark Green Powder Coat

GC - Gray Powder Coat

SC - Special Colors\*

\*Provide RAL # or Sample Color Chip

### Mounting Options

#### Tenon Mount

For Tenon Mount applications specify both Tenon diameter and length.



#### Side Drill Mount

Includes removable pole cap.

NOTE: A luminaire drilling template must be supplied at time of order.



### Drill Mount Options

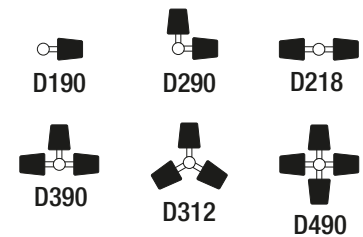

### Pole Orientation

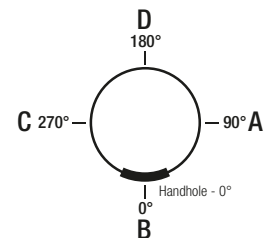

CATALOG NUMBER:	QUANTITY:
CUSTOMER NAME:	
PROJECT:	LOCATION:
NOTES:	