

RTA

Round Tapered Aluminum Pole No Arm — Hinged Base

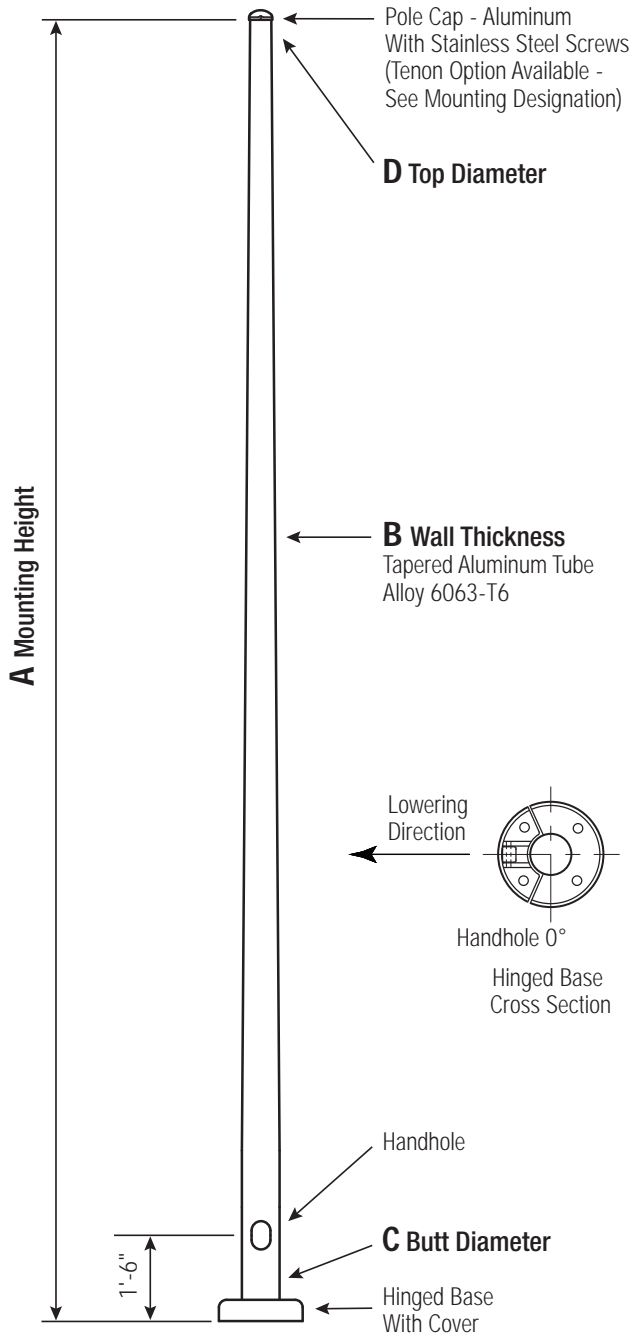

Satin Aluminum or Powder Coated Finish per Customer Specification.

C BUTT DIA.	D TOP DIA.	F BOLT CIR. DIA.	G COVER DIA.	H BOLT PROJ.	I BOLT SIZE
4	3	7	9.75	2	.75 x 17 x 3
5	3	8.5	11.25	2	.75 x 17 x 3

Dimensions in Inches

Pole

The pole shaft will be constructed of seamless extruded tube of 6063 Aluminum Alloy per the requirements of ASTM B221. The shaft assembly shall be full-length heat treated after base weld to produce a T6 temper.

Base Style

Hinged Cast Aluminum Base Flange of Alloy 356-T6 with 2-Piece Cast Aluminum Base Cover and Stainless Steel Tamper-Resistant Attaching Screws.



Handhole

2" x 4" Handhole with curved Lap Style Aluminum Door and two (2) Stainless Steel Self-Tapping Attaching Screws. A Grounding Provision incorporating a tapped 1/4"-20NC hole is provided.



Anchorage

Anchorage Kit will include four (4) L-shaped Steel Anchor Bolts conforming to AASHTO M314-90 Grade 55. Ten inches (10") of Threaded End will be Galvanized per ASTM A153. Kits will contain four (4) Hex Nuts, four (4) Lock Washers, and four (4) Flat Washers (all components Galvanized Steel). A bolt circle template will be provided.

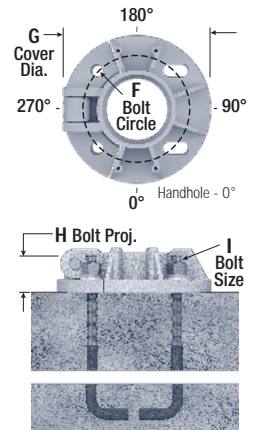

Vibration Damper

When determined necessary by Hapco, a Vibration Damper will be factory-installed inside the pole shaft. Customer specification of the damper is available.

Mounting Designation

Side Drill Mount

For Side Drill Mount applications specify luminaire type, quantity and orientation. A luminaire drilling template must be supplied at time of order.

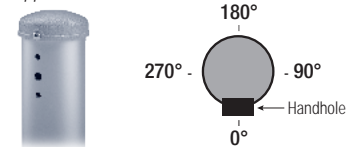

Tenon Mount - Welded or Spun

For Tenon Mount applications specify both Tenon diameter (2.375", 2.875", 3.5", etc.) and length (3", 4", etc.). Tenon style is factory option. Welded Tenon can be specified.



www.hapco.com

FLORIDA BUILDING CODE GUIDE
2017 FBC EPA'S

WARNING: Do not install light pole without luminaire.

A Mtg. Hgt.	B Wall Thickness	C Butt Dia.	TOTAL LUM. WEIGHT	MAXIMUM EPA								OLD CATALOG NUMBER	CATALOG NUMBER
				120	130	140	150	160	170	180			
06	0.125	4	110	11.1	9.4	8.0	6.9	6.0	5.2	4.6	73142-001	RTA06B4AH-**	
08	0.125	4	80	7.9	6.6	5.6	4.7	4.1	3.5	3.1	73142-002	RTA08B4AH-**	
08	0.156	4	95	9.8	8.2	7.0	6.0	5.1	4.5	3.9		RTA08C4AH-**	
08	0.188	4	115	11.7	9.8	8.3	7.1	6.2	5.4	4.7		RTA08D4AH-**	
10	0.125	4	60	5.9	4.8	4.0	3.3	2.8	2.3	2.0	73142-003	RTA10B4AH-**	
10	0.156	4	75	7.4	6.1	5.1	4.3	3.6	3.1	2.6		RTA10C4AH-**	
10	0.188	4	90	8.8	7.3	6.2	5.2	4.4	3.8	3.3		RTA10D4AH-**	
10	0.125	5	115	11.5	9.6	8.1	6.9	6.0	5.2	4.6	73142-011	RTA10B5AH-**	
10	0.156	5	145	14.4	12.1	10.2	8.8	7.6	6.6	5.8		RTA10C5AH-**	
12	0.125	4	45	4.4	3.5	2.8	2.3	1.8	1.4	1.2	73142-004	RTA12B4AH-**	
12	0.156	4	60	5.6	4.6	3.7	3.0	2.5	2.1	1.7		RTA12C4AH-**	
12	0.188	4	70	6.8	5.6	4.6	3.8	3.2	2.7	2.2		RTA12D4AH-**	
12	0.125	5	90	9.1	7.5	6.2	5.3	4.5	3.8	3.3	73142-008	RTA12B5AH-**	
12	0.156	5	115	11.5	9.5	8.0	6.8	5.8	5.0	4.4		RTA12C5AH-**	
14	0.125	4	40	3.2	2.4	1.8	1.4	1.0	0.7	-	73142-005	RTA14B4AH-**	
14	0.156	4	45	4.3	3.4	2.6	2.1	1.6	1.2	1.0		RTA14C4AH-**	
14	0.188	4	55	5.3	4.2	3.4	2.7	2.2	1.7	1.4		RTA14D4AH-**	
14	0.125	5	75	7.2	5.8	4.8	3.9	3.3	2.8	2.3	73142-009	RTA14B5AH-**	
14	0.156	5	95	9.2	7.6	6.3	5.2	4.4	3.8	3.3		RTA14C5AH-**	
16	0.156	4	40	3.1	2.3	1.7	1.2	0.8	-	-		RTA16C4AH-**	
16	0.188	4	45	4.0	3.1	2.4	1.8	1.3	1.0	0.7		RTA16D4AH-**	
16	0.125	5	60	5.6	4.4	3.5	2.8	2.3	1.9	1.5	73142-010	RTA16B5AH-**	
16	0.156	5	75	7.4	5.9	4.8	4.0	3.3	2.7	2.3		RTA16C5AH-**	
18	0.125	5	45	4.2	3.2	2.5	1.9	1.4	1.1	0.8	73142-006	RTA18B5AH-**	
18	0.156	5	60	5.7	4.5	3.6	2.9	2.3	1.9	1.5		RTA18C5AH-**	
20	0.125	5	40	3.0	2.2	1.5	1.0	0.7	-	-	73142-007	RTA20B5AH-**	
20	0.156	5	50	4.4	3.3	2.5	1.9	1.4	1.1	0.8		RTA20C5AH-**	

Catalog Number System

The catalog number for Hapco poles utilizes the following identification system.

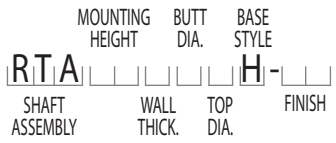

Catalog Number Example -

RTA 20 C 5 A H - 01

Round Tapered Aluminum, 20' Mounting Height, .156" Wall Thickness, 5" Butt Diameter, 3" Top Diameter, Hinged Base, Satin Aluminum Finish.

Wall Thickness

- B = .125"
- C = .156"
- D = .188"

Butt Diameter

- 4 = 4"
- 5 = 5"

Top Diameter

- A = 3"

Base Style

- H = Hinged Base

Finish

- O1 = Satin Aluminum
- BA = Black Powder Coat
- BH = White Powder Coat
- BM = Dark Bronze Powder Coat
- BV = Dark Green Powder Coat
- GC = Gray Powder Coat
- ** = Specify Finish

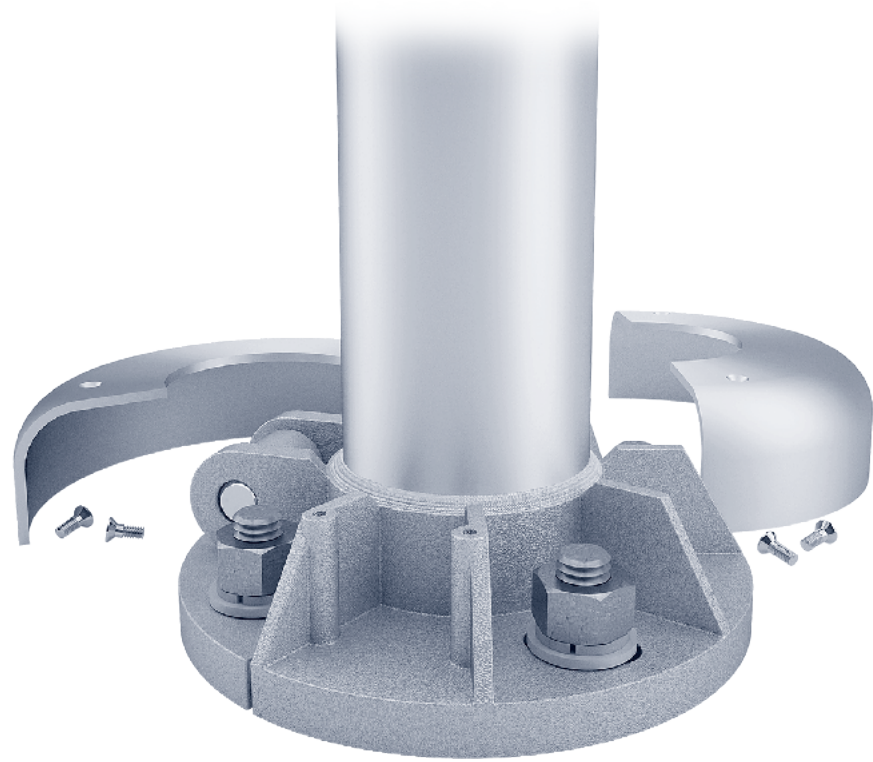

EPA Note:

EPA's based on symmetrically placed side mounted fixture(s) not exceeding height of the pole.

