

ALUMINUM... THE RIGHT CHOICE!



Better than Steel. Better than Concrete. Better than Composite.
Aluminum Light Poles Are The Best Choice Period.



History

Hapco has a long history dating to 1843 when its parent corporation, Hubbard and Company, originated as a national manufacturer of forgings and stampings to the utility industry. A major contributor to the emerging telephone and power industries of the late 19th century, their commitment to “offering products of the highest quality at ever-increasing service levels” established Hubbard as the leading company in these growing fields.

In 1951, Hubbard established a new division, the Hubbard Aluminum Products Company (HAPCO), and offered its first line of aluminum lighting poles and brackets in August of that same year. The superior properties of aluminum poles were immediately embraced by the market, with Hapco seeing significant growth during these early years.



Hapco was acquired by our current owner Dyson-Kissner-Moran (DKM) in 1958, and the original Pittsburg, Pennsylvania facility was moved to our present-day location in Abingdon, Virginia in 1962. Today, after over 50 years and multiple plant expansions, our skilled workforce continues to vigorously pursue our founder’s original commitment of “the highest quality” products in the light pole industry.

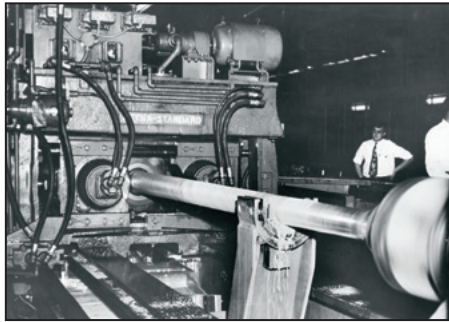

Hapco Archives – Circa 1951

Engineering Excellence

“By adopting the latest methods of...fabrication combined with expert engineering knowledge of the many alloys of aluminum and their properties, Hapco Products are maintained at the highest level of quality.”

Hapco Product Catalog Number 60, 1955

As a manufacturer forging the way in aluminum pole production for over 60 years, Hapco is at its core a company with a passion for excellence in innovation and product quality. The formula for this success hasn’t changed since 1955, as the statement above is as true about Hapco today as it was then.

“Engineering Knowledge” has been instrumental in carrying Hapco from an industry pioneer to today’s recognized leader in the aluminum pole industry.

Our advanced technical skill and in-depth metallurgical knowledge of aluminum is unequalled, earning Hapco a respected reputation for both our design capabilities and product quality. Our hundreds of combined years of engineering experience are focused on Hapco’s “Better By Design” pledge, and the results of our commitment to excellence can be seen in our exclusive Lifetime Warranty.



Manufacturing Expertise

Hapco's entry into aluminum pole products manufacturing was undertaken with a simple philosophy...to provide our customers superior street and area lighting products through the investment and implementation of the most advanced machinery and manufacturing processes of the day. This philosophy led to several firsts in the market, including one-piece aluminum poles in lengths to 40' and the use of automatic ovens for accurate regulation of the heat treat cycle.



Today, this "Best-in-Class Manufacturing" mentality continues with the most advanced, state-of-the-art aluminum manufacturing technologies incorporated into our 335,000 square foot facility. Decades of experience are combined with automated on-site powder paint facilities, on-site fluting, dedicated custom lines and a full embracement of the principles of Lean Manufacturing.

After over six decades our manufacturing expertise continues to produce products of the highest quality, earning Hapco a respected reputation for excellence and making Hapco one of the most recognized...and specified...names in the light pole industry.



Dedicated Research and Development

Hapco has a proud history of dedicated involvement in the research that shaped the industry, with decades of active participation in organizations such as The Aluminum Association, the National Electrical Manufacturers Association (NEMA), the National Cooperative Highway Research Program (NCHRP), and the American Association of State and Highway Transportation Officials (AASHTO). This background and experience provides the solid foundation for our leading Research and Development program.

Hapco's commitment to R&D can be observed in our fully-equipped, in-house R&D labs and testing facilities. In addition, Hapco has an on-site crash test pendulum that provides the means to test full-scale poles and brackets at our Abingdon, VA campus. Thousands of tests have been conducted through the years in the interest of product improvement and safety, playing a major role in earning Hapco the reputation of providing the highest quality aluminum pole products.

This dedication to in-house testing, combined with extensive research projects performed in collaboration with accredited university testing labs, have led to many industry-recognized contributions to aluminum pole development. Hapco initiated the first wind tunnel testing to insure more efficient product designs, and our early work on vibration control and breakaway safety led to the first industry patents awarded in these categories.

Table of Contents

- The Aluminum Advantage 4-5
- Hapco Specification Advantage . . . 6-7
- LED / Proven Performance 8-9
- Direct Buried 10-11
- Aluminum vs. Composite. 12-13
- Aluminum vs. Concrete. 14-15
- Aluminum vs. Steel. 16-17
- Decorative - Structural Base . . . 18-19
- Decorative - Clamshell Base . . . 20-21
- Breakaway 22-25
- Smart Pole Solutions 26-27
- Hapco Solutions 28
- Custom Capabilities 29
- Lifetime Warranty 30
- The GREEN Choice 31

Cover Photo Courtesy

New York State Thruway Authority
Governor Mario M. Cuomo Bridge
(Replacing the original Tappan Zee Bridge)

Hudson River
Rockland and Westchester Counties, New York
(25 miles north of NYC)



Hapco's custom aluminum 5-degree tilt pole with custom vibration dampening system and 100-year design life criteria were a perfect fit for Hapco's pledge of "Better By Design"!

See Bridge Case Study
<http://www.hapco.com/case-studies>

Corrosion Resistant

Aluminum is naturally resistant to corrosion and may be left unpainted. On contact with air it forms a resistant layer of aluminum oxide that guards against corrosion. Hapco round poles are constructed of aluminum alloy 6063, a highly weldable marine grade alloy also used in the manufacture of boat hulls. This alloy exhibits extremely high resistance to corrosion when compared to ferrous-based products.



Nature's Protective Coating... Aluminum Oxide

- Raw aluminum is very reactive with atmospheric oxygen. Oxidation occurs naturally and immediately when raw aluminum is exposed to air.
- Oxygen molecules in the air chemically bond with the aluminum surface to produce a continuous layer of Aluminum Oxide (Al_2O_3).
- Aluminum Oxide becomes an integrated part of the parent aluminum material, creating a strong, impenetrable layer.
- Aluminum Oxide is one of the hardest substances known. On the Mohl's Hardness Scale, aluminum oxide's hardness is rated at 9. The scale ranges from 1 to 10 (*with 10 being the hardest*). For comparison, diamonds have a Mohl hardness of 10.
- The Aluminum Oxide layer of protection will not wear out over time and is immediately self-healing if damaged or scratched.
- The Aluminum Oxide layer impedes further reaction with the environment, permanently protecting the metal from further oxidation.

Durable

Aluminum light poles have been in use for over 60 years, and many of the original installations are still in service without structural problems or noticeable difference in appearance. The fact that aluminum is maintenance-free allows it to be a tremendous value when the overall cost of pole ownership is considered.

Lightweight

Aluminum is lightweight, allowing for easier installation than steel which provides savings in both labor and equipment. In fact, aluminum is approximately one-third the weight of steel, making it much easier to handle and less expensive to ship. Aluminum has a high strength-to-weight ratio. Pound for pound, it is stronger than steel.



Flexible Design

Aluminum is used in breakaway designs, offering greater breakaway safety.

Hapco is an industry leader in breakaway provisions and design, offering the following Federal Highway Administration (FHWA) accepted breakaway devices:

- **Anchor Base** – Saves installation and hardware costs and improves aesthetics. Anchor bases cannot be used with steel.
- **Couplings** - Widely used.
- **X-Base** (*unique to Hapco*) – Saves installation and hardware costs and improves aesthetics. X-Bases cannot be used with steel.
- **Transformer Base "T-Base"** – Industry standard and widely used.
- **Direct Buried Poles** (*unique to Hapco*) – Direct buried poles can provide significant savings, eliminating the need for the foundation, base, and hardware. Aluminum poles are used in direct buried applications throughout the country, having over 60 years of successful installations. Cannot be offered with steel.
- **Decorative Bases** – Hapco currently offers more FHWA accepted Decorative products than any other manufacturer, including several direct buried applications (*unique to Hapco*). Savings result from the elimination of couplings and skirts and foundations on direct buried poles, and result in dramatically improved aesthetics.

Easy to Clean, Including Graffiti

Satin finished poles can be treated with solvents or sanded to remove unwanted paint without compromising the corrosive resistance or the finish.

Valuable

Aluminum offers significantly higher scrap value than steel, allowing a return on investment in the event of a knock down. The scrap value of aluminum is more than ten times that of steel.

The “Green” Choice

Aluminum provides an environmentally responsible choice of material and approach within the burgeoning green movement. It is the most abundant mineral in the earth’s crust, and unlike the galvanization process of steel which emits zinc chloride and ammonium chloride into the atmosphere, has a low impact on the environment. Aluminum is 100% recyclable and can be recycled without losing any of its superior characteristics or integrity, making it appealing from both environmental and economic criteria. Simply put, Aluminum never has to be thrown away, has an incredibly long life cycle, and allows specifiers to aggressively pursue a design that will be based upon sustainable principles.



Maintenance-Free

Hapco aluminum is near-zero maintenance, providing the lowest overall cost of pole ownership.



ALUMINUM Provides a Lower Overall Cost of Ownership

The properties of aluminum make it a tremendous value when the overall cost of ownership is considered. Higher installation and maintenance costs for aluminum alternatives, combined with guaranteed replacement costs of shorter lifecycle materials, contribute to aluminum having the lowest cost of ownership of any lighting pole option.

Durable Powder Coating

Hapco uses Super Durable Thermoset Powders as the standard for all powder coated poles. Super Durable is designed specifically for architectural applications where color and gloss retention is critical. The American Architectural Manufacturers Association (AAMA) provides classifications for powder coating.

These specifications have been widely recognized as the standards for powder coating. AAMA classifies Super Durable Powder as AAMA 2604. Super Durable Powder is formulated with advanced polyester resin technology that utilizes higher performance pigments, providing superior gloss and color retention over the powder coating that many manufacturers use as their standard (AAMA 2603).

Powder Coating is compliant with environmental regulations without the release of Volatile Organic Compounds (VOC’s), as opposed to liquid paints which must contain solvents. Liquid paints release VOC’s into the atmosphere, contributing to pollution. Additionally, there is no hazardous waste from the powder coating process.

AASHTO Approved

With the in-house Design Engineering team, Hapco will assist in the design of poles. Maximizing project funds is essential. For this reason, it is important to utilize materials properly, as selecting the precise pole for a project may result in significant savings. The Hapco Engineering team can design and manufacture poles to AASHTO specifications or applicable local building codes.

All Hapco poles are designed to American Association of State Highway & Transportation Officials (AASHTO) standards. Not all manufacturers design to AASHTO, which is conservative by nature. Hapco also meets applicable material ASTM standards. All welders are American Welding Society (AWS) certified.



Tapered Poles

The ability to taper an aluminum pole is the single greatest difference between Hapco and other pole providers. As one of the very few manufacturers in the country that can taper aluminum poles, Hapco offers a distinct advantage over pole providers that purchase tapered aluminum and resell it to their customers.

Customer Benefit:

- A tapered pole is a more efficient pole. Less wind deflection at the top allows for an increase in EPA, resulting in the ability to specify a lighter pole. The taller a pole, the more this is magnified.
- A tapered pole looks better. This is particularly true when using a post top fixture. It allows for a much more attractive transition. Most poles will be tapered to a three inch top which transitions to a 3" post top perfectly. Most round straight poles will be at a minimum top OD of 4". This results in a larger pole transitioning to a smaller post top fixture.

Sample Taper Specification

The shaft shall be constructed of seamless extruded tube of 6063 aluminum alloy per the requirements of ASTM B221 of sufficient nominal thickness to meet the design requirements without the use of internal reinforcing sleeve. No longitudinal shaft welds shall be allowed. The spun tapered shaft shall have a nominal (x)-inch outside bottom diameter and a (x)-inch outside top diameter with a minimum nominal wall thickness of (x). The shaft shall have a flush (x)-inch by (x)-inch reinforced hand hole with an aluminum cover. The cover shall be secured with stainless steel screws. The handhole frame will have a 3/8"-16NC tapped hole for grounding. The shaft shall be full-length heat-treated after welding on the base flange to produce a T6 temper. The heat-treating oven used shall be certified to meet the requirements of ASTM B597 and Mil-H-6088 specifications.

Performance Specifications

Hapco customers may specify performance specifications that allow a pole to meet loading requirements as opposed to a specified wall and diameter specification. Hapco is able to manufacture lighter poles due to its heat treating process. Hapco purchases aluminum extrusions in a T4 Temper. After tapering and welding, the poles are then baked (*heat treated*) in an oven at 350 degrees for six and one half hours, increasing the temper to T6. This increased strength allows Hapco to build a pole to required loading while using less material than much of the competition. If a manufacturer cannot heat treat, they must use larger diameter or thicker walls to meet the same EPA.

Customer Benefit:

- A stronger, more efficient pole.

Sample Design Specification

The pole shall conform to the requirements of the "Standard Specifications for Structural Supports for Highway Signs, Luminaires and Traffic Signals, 2001 LTS4" by The American Association of State Highway and Transportation Officials for a basic wind speed of (x) mph when supporting a luminaire having a maximum effective projected area (EPA) of (x) ft² and a maximum weight of (x) lbs.



Heat Treating After Welding

When poles are welded to a base, the weld becomes the weakest part of the pole. Thicker walled poles must be used to compensate for this weakness. A stronger pole reduces the stress load on the weld. Heat treating after weld strengthens the weld by 70%. This allows Hapco to use thinner walled poles to achieve the same EPA. Many competitors do not have the ability to heat treat, forcing them to use thicker materials resulting in more expense.

Customer Benefit:

- A more efficient pole which results in cost savings.

Sample Heat Treat and Welding Specification

Heat Treating: The shaft shall be full-length heat treated after welding on the structural base to produce a T6 temper. The heat treating oven used shall be certified to meet the requirements of ASTM B597 and Mil-H-6088 specifications.

Welding: Welding shall be done by the inert gas shielded metal arc method with consumable electrode. Aluminum alloy 4043 electrode shall be used. Welding shall be in accordance with AWS Specification D1.2, Structural Welding Code - Aluminum.

AAMA 2604 (Super Durable) Powder Coating

The American Architectural Manufacturers Association (AAMA) provides classifications for powder coating. These specifications have been widely recognized as the standards for testing and performance of organic coatings on architectural aluminum extrusions and panels. AAMA 2604 is known as Super Durable powder coat which is formulated with advance polyester resin technology that utilizes higher performance pigments. While many other manufacturers use the lesser 2603 as the standard, Super Durable 2604 is Hapco's standard powder coat. AAMA makes Southern Florida the benchmark for testing due to its extreme weather conditions. They guarantee Super Durable 2604 to withstand outdoor exposure for 5 years as opposed to 1 year for standard 2603.

AAMA 2604 (*Super Durable*) Powder Coating *(continued)*

Customer Benefit:

- Superior gloss and color retention over standard polyesters.
- Superior weathering capabilities.
- Better exterior durability, UV resistance and gloss retention. Accepts and holds onto electrical charge better and longer than standard powders.
- Reduces the overall cost of ownership of the pole by providing longer lasting aesthetics.

Sample Powder Coating Specification

Powder coating material shall be a Super Durable thermosetting polyester powder coating. A minimum coating thickness of 2 mils shall be maintained. Application of powder shall be electrostatically applied by a closed loop automated powder coating system featuring eight automatic spray guns with computerized controls to ensure mil thickness conformance. The powder coating system shall employ a powder recovery system utilizing closed loop quick-change technology to achieve efficient and contamination free color changes. The powder shall be applied only when both the ambient and part temperatures are 50 degrees Fahrenheit or above. Once powder coated, the product shall proceed through a curing oven operating at 400 degrees Fahrenheit that has been surveyed and certified for temperature uniformity. The product shall move continuously through the oven from beginning to end and shall attain the time at temperature in accordance with the paint manufacturer's recommendations. Once oven cured, the product shall move immediately to and continuously through a cooling tunnel designed to restore the product to acceptable packaging temperature prior to inspection and packaging. Upon exiting the cooling tunnel the product shall be immediately inspected and packaged.

Surface Preparation Prior to Powder Coat

Proper surface preparation ensuring that items are contamination free prior to powder coating is a major factor in the achievement of a long lasting and adhering coating. If items become contaminated prior to powder coating, the powder will not bake/bond to the item properly. This is the most commonly seen reason for powder coat to peel or flake off of installed poles. Hapco utilizes a state-of-the-art shot blasting system. To further ensure contamination free products, the shot blasting facility is a mere six yards from the powder coat system.

Customer Benefit:

- Proper adhesion of the powder coat to the item, assuring a long aesthetic life.
- Uniform powder coat as pole and base run through the system together.

Sample Surface Preparation Specification

Pole shafts shall be shot blasted utilizing automated shot blast equipment with specifically designed shadow patterning to achieve 360 degree coverage. The line speed shall be automated and shall be controlled to ensure uniform surface preparation. As a part of the integrated system, to ensure that the prepared parts are kept clean and not exposed to dirt, dust, grease or oil and to ensure maximum powder coat adhesion, the product shall proceed continuously and immediately to the powder coating process within the same facility where the poles and arms are manufactured.

AASHTO Specifications or Local Building Codes

All standard Hapco poles are designed to American Association of State Highway & Transportation Officials (*AASHTO*) standards, which is conservative by nature. Not all manufacturers design to AASHTO, with many having denotations under their EPA tables similar to the following: All EPA values are calculated by the factory...if EPA's calculated per AASHTO are needed, please consult the factory. These disclaimers allow them to make the EPA's whatever they desire.

Hapco designs to AASHTO specifications because pole failure is not an option, and our commitment to quality and safety is validated by our Lifetime Warranty on Aluminum pole assemblies.

The Hapco Design Engineering team can also design poles to applicable Local Building Codes such as the Florida Building Code. We have the expertise to assist project owners in selecting the precise pole for a project, which can result in significant cost savings.

In addition, Hapco meets applicable ASTM material standards, and welding is performed by gas metal arc welding in accordance with American Welding Society (*AWS*) or Canadian Standards Association (*CSA*) specifications.

Customer Benefit:

- Assurance of the proper pole for the job through access to industry-leading Design, Engineering, and Manufacturing.
- Confidence that the poles are built to specification.

Aluminum Alloy 356

Hapco base castings are specified exclusively with Aluminum Alloy 356. Competitors commonly use Alloy 319 which contains 4% Copper content in the alloy. Unlike Aluminum, Copper will corrode, causing premature cracking and peeling of applied coatings. Aluminum Alloy 356 is a superior alloy that contains no copper.

Customer Benefit:

- A higher quality alloy containing 0% Copper equals zero corrosion, guaranteeing Hapco customers enhanced aesthetics.



Hapco Aluminum Poles and LED Lighting

Why erode the benefits of **LED Lighting** with high-maintenance lighting poles that have shorter life-cycles and are inherently less aesthetic than aluminum?

A completed assembly containing **LED Fixtures** and **Hapco Aluminum Poles** guarantee project owners the proven performance, longevity and superior aesthetics of aluminum with the **Specification Advantages** and **Lifetime Warranty** that can only be delivered by Hapco.

Hapco Aluminum is the "LED" of Lighting Poles!



"Specify HAPCO Aluminum Poles"

Hapco Aluminum Poles and LED's...Lighting the streets of Detroit.

See Detroit Case Study

<http://www.hapco.com/case-studies>

Hapco standard and decorative aluminum products

are used in various applications in the Commercial, Utility, Municipality, Department of Transportation and Communication markets. For over 60 years, Hapco has been considered a leader in the light pole industry and has products in every state of the US, Puerto Rico, and several international countries. Our history of proven performance, coupled with our exclusive Lifetime Warranty on aluminum pole assemblies, make Hapco the trusted industry source.

A partial listing of our customers is shown below:



*Venetian Causeway
Miami, FL
Installed Circa 1951*

Utility

Alabama Power
Alliant Energy
American Electric Power
Austin Energy
Baltimore Gas & Electric
Bristol Tennessee Essential Services
Bristol Virginia Utilities
Brownstown Electric
Chattanooga Power Board
Colorado Springs Utility
Consumers Energy
Dayton Power & Light
Detroit Energy
Dominion Power
Duke Energy
Electric Services
Entergy
First Energy
Harrisonburg Electric Commission
Huntsville Utilities
Indianapolis Power & Light
Jackson Electric Authority
Johnson City Power Board
Kentucky Utilities
Knoxville Utility Board
Louisville Gas & Electric
Mississippi Power Company
Nashville Electric Commission
National Grid
Niagara Mohawk
Northeast Utilities
Ocala Utilities Board
Orlando Utilities Commission
Pacific Gas & Electric
Progress Energy
PSE & G
Public Services of New Mexico
Puget Sound Energy
South Carolina Electric & Gas
Southern Company
Tampa Electric Company
Virginia Tech Electric
Xcel Energy

Light Fixture Manufacturers

GE Lighting
Holophane
Hubbell
Lithonia

Department of Transportation

Alabama
Arizona
California
Colorado
Connecticut
Florida
Georgia
Hawaii
Illinois
Indiana
Kansas
Kentucky
Louisiana
Maine
Maryland
Massachusetts
Michigan
Minnesota
Mississippi
Nevada
New Jersey
New Mexico
New York
North Carolina
Ohio
Oregon
Pennsylvania
Rhode Island
South Carolina
Tennessee
Texas
Virginia
Washington
Wisconsin

Municipalities

Albuquerque, New Mexico
Atlanta, Georgia
Austin, Texas
Baltimore, Maryland
Birmingham, Alabama
Champagne, Illinois
Charleston, South Carolina
Chattanooga, Tennessee
Chicago, Illinois
College Station, Texas
Colorado Springs, Colorado
Columbus, Ohio
Dayton, Ohio
Des Moines, Iowa
Eau Claire, Wisconsin
Fargo, North Dakota
Fort Wayne, Indiana
Grand Forks, North Dakota
Greenville, South Carolina
Gulfport, Mississippi
Huntsville, Alabama
Indianapolis, Indiana
Jacksonville, Florida
Kansas City, Kansas/Missouri
Knoxville, Tennessee
Las Cruces, New Mexico
Lexington, Kentucky
Louisville, Kentucky
Madison, Wisconsin
Milwaukee, Wisconsin
Minneapolis, Minnesota
Mobile, Alabama
Nashville, Tennessee
New York, New York
Ocala, Florida
Ogden, Utah
Orlando, Florida
Park City, Utah
Pensacola, Florida
Philadelphia, Pennsylvania
Savannah, Georgia
Seattle, Washington
Tacoma, Washington
Tampa, Florida
Numerous Co-Ops and
Metered Municipalities

Military Bases

Brookley AFB
Camp Lejeune
Elgin AFB
Fort Benning
Fort Bliss
Fort Bragg
Fort Campbell
Fort Carson
Fort Drum
Fort Gordon
Fort Huachuca
Fort Jackson
Fort Lee
Fort Riley
Fort Rucker
Fort Sill
Fort Stewart
Grand Forks AFB
Kings Bay Naval Base
MacDill AFB
White Sands Missile Base

Direct Buried Aluminum Poles

Faster, More Cost Efficient Installations

Aluminum poles used in direct buried applications throughout the country have a 60 year record of successful installations and can provide significant overall job savings.



Hapco Aluminum Direct Buried Pedestal Poles are the perfect solution to the high maintenance alternative of composite poles. Utilities, Developers and Contractors can benefit from the savings associated with the highest quality, longest-lasting and lowest maintenance direct buried alternative for residential applications.

Advantages

- Ease of installation.
- Eliminates the need for foundations, requiring no Civil Engineer and no PE stamp, resulting in cost savings of \$300 - \$1000.
- Eliminates the need for bolt circle templates and anchor bolts.
- Speeds up the installation process while eliminating the additional freight charges of anchor bolts shipped in advance.
- Eliminates the use of shims or double nuts for leveling.
- Eliminates improper bolt projections that in many instances result in high and uneven base covers.
- Eliminates the need, time and expense to grout.
- Eliminates the possibility of foundation and anchor bolt replacement in the event of a knockdown.
- Allows aluminum to be cost competitive with composite and concrete while providing a more appealing and aesthetic appearance.
- Eliminates the possibility of improper pouring/setting of foundation.
- Allows simple future retrofits by eliminating the need to match an existing bolt circle.
- Eliminates base plate weld, providing longer fatigue life and reduced chance of failure.
- Ground acts as a natural damper, reducing the risk of wind induced vibration.
- Provide greater EPA values than anchor base designs by eliminating the weld joint, offering approximately 18-20% more strength. In many instances this allows a one wall size reduction, leading to a price reduction.

Example...Changing a 7" Dia., 25' MH, .188" wall, anchor base design to a like pole with a .156 wall, direct buried design (similar EPA values on both designs).

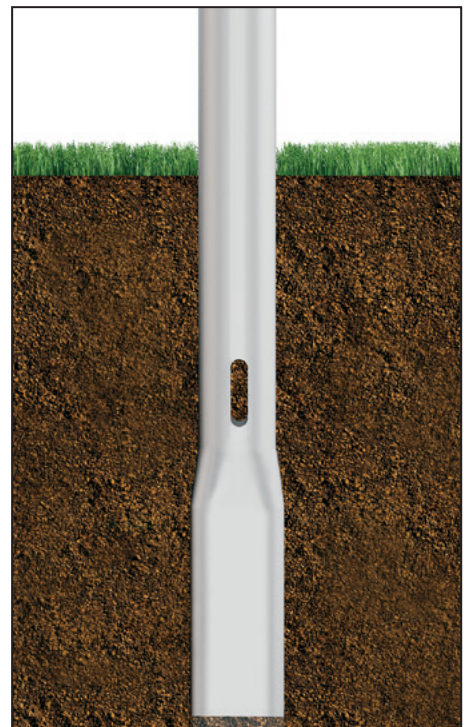

Lifetime Warranty
Exclusively with Hapco Aluminum

Direct Buried Aluminum Opportunities

**Reduce Cost.
Improve Aesthetics.**

**Save on your
next project!**



Examples of Anchor Base installations that are perfect opportunities for Hapco's Direct Buried Aluminum Poles.



Naturally Corrosion Resistant!

Hapco's Exclusive Lifetime Warranty* guarantees against corrosion, INCLUDING Direct Buried Applications.



Looking for examples of direct buried installations in your area?

Direct Buried Aluminum flagpoles have a 60 year history of successful installations.

**Excludes installation in soils with a pH under 5 or over 9 and improper grounding.*



The Aluminum Advantage

The ADVANTAGES of Hapco Aluminum versus Composite are significant...

- Aluminum is naturally Corrosion Resistant, making it the perfect choice for Direct Buried applications.
- Aluminum is not affected by ultraviolet fading and fiber blooming, resulting in savings from costly repainting and replacement.
- Aluminum poles are heat treated after weld to a full T6 temper, giving them superior resistance to cuts and abrasions from trimmers and mowers.

Hapco Exclusive Lifetime Warranty

Composite
Less Strength –
Easy Product Failure

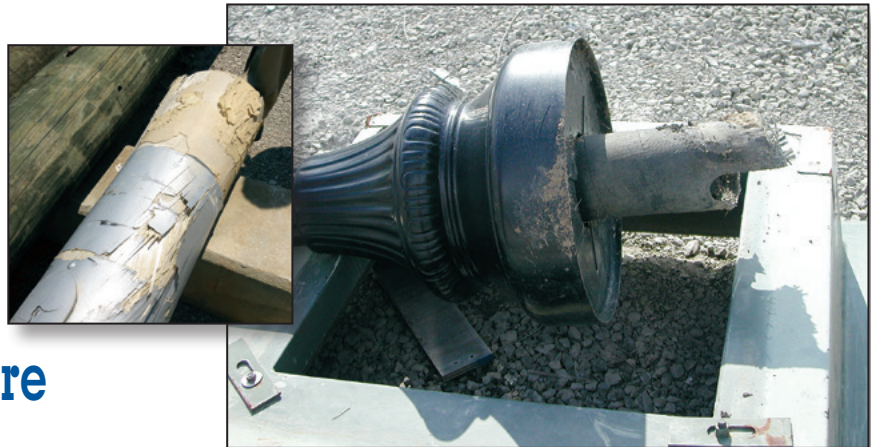

Composite
Lawn Mower and
Weedeater Damage

Composite Paint Issues

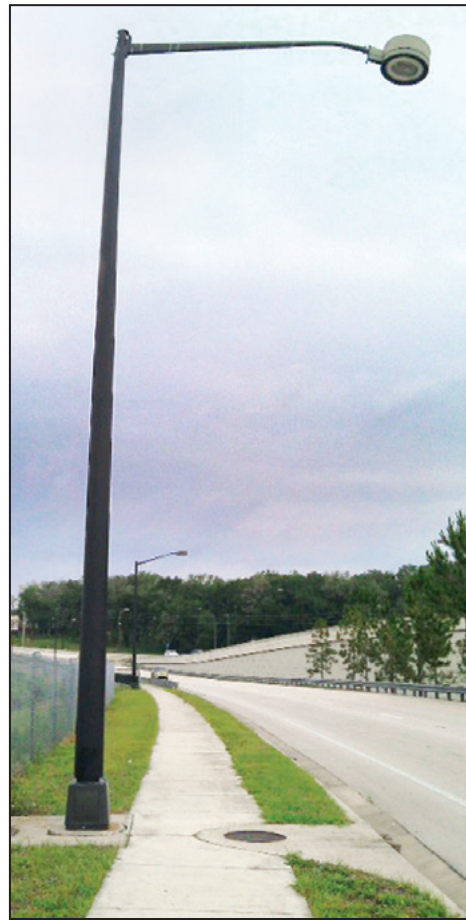

Composite
Deflection



Composite
Plastic Bases



Composite
Poor Aesthetics

When compared to Concrete, the Advantages of Aluminum Poles are substantial.



Advantages of Aluminum

The superior properties of aluminum make it both the perfect choice and best value for lighting poles.

- Superior Aesthetics
- Lifetime Warranty
- Lower Overall Cost of Ownership
- Lightweight
- Corrosion Resistant
- Near-Zero Maintenance
- High Recycle Value - 100% Recyclable Material
- Proven Performance

Concrete



Poor Aesthetics

Rust Stains

Costly Tenon Adapters

Band Mounted Accessories

Harsh Transitions

Spalling (*Crumbling*)

Heavy

Higher Shipping and Labor Costs

Why Concrete Poles are NOT YOUR BEST Direct Buried Alternative.

Concrete Poles

- Concrete is much heavier than Aluminum, resulting in significantly higher shipping and labor costs.

25' Mounting Height Comparison
Aluminum pole = 140 lbs.
Concrete Pole = 1100 lbs.

- Concrete's slower, less efficient installations translate into extended job completion times.
- Concrete is difficult to install, requiring expensive installation equipment and larger installation crews.
- Concrete requires costly tenon adapters, which often loosen over time, causing vibration damage to the pole and/or fixture. Aluminum can be side drilled.
- Concrete is bulky, creating awkward transitions to today's sleek LED fixtures.
- Concrete has limited wire entry flexibility. Aluminum poles can be slotted up to 2" x 5" at 180°.
- Concrete poles use less aesthetic band mounting for accessory connections which leave stain rings when removed.
- Concrete will develop stains. Rebar used inside the pole will rust. The porous nature of the concrete allows this rust to bleed through to the surface of the pole, resulting in visible rust stains. Reclaimed waste water used by sprinkler systems many times contain iron, which permeates the porous concrete, also creating rust stains. Ground surface staining, especially in red clay environments, will also occur.

ALUMINUM INSTALL COST	VS	CONCRETE INSTALL COST
1 @ \$41/hr	LINEMAN	1 @ \$41/hr
n/a	OPERATOR	1 @ \$36/hr
1 @ \$28/hr	APPRENTICE	1 @ \$28/hr
n/a	LABOROR	1 @ \$14/hr
n/a	TRUCK	1 @ \$14/hr
1 @ \$115/hr	BUCKET TRUCK w/auger	1 @ \$115/hr
1 @ \$6/hr	TRAILER	1 @ \$6/hr
45 mins.	INSTALL TIME	1.5 hrs
\$190 per pole	INSTALL COST* <small>*Rates per hour with fringe.</small>	\$382 per pole

ALUMINUM IS MUCH LIGHTER THAN CONCRETE, RESULTING IN LOWER LABOR COSTS.

25' = 140 lbs
MH ALUMINUM POLE

25' = 1100 lbs
MH CONCRETE POLE

Faster, more efficient installation translates into quicker job completion allowing the contractor to move to the next project faster. The average of 8-10 CONCRETE POLES installed a day VERSUS 15-18 ALUMINUM POLES installed a day results in significant time and cost savings.

- Concrete is conducive to spalling. Corrosion of reinforcing steel embedded in concrete lighting poles is a leading cause of deterioration. When steel corrodes, the resulting rust occupies a greater volume than the steel. This expansion creates tensile stresses which eventually causes cracking, delamination, and spalling (or crumbling) of the concrete.
- Concrete is susceptible to salt spalling, a specific type of weathering which occurs in porous building materials. Dissolved salt is carried through the material in water and crystallizes inside the material near the surface. As the water evaporates, the salt crystals expand, building up shear stresses which break away spall from the concrete surface.
- Concrete has poor aesthetics due to a lack of uniformity of color between the pole, fixture, and pole accessories such as banner arms and flag holders.
- Concrete handholes are trapezoidal, resulting in smaller handhole access. Junction boxes and submersible connections often must be used, resulting in poor aesthetics and increased costs up to \$200 per pole. Aluminum flexibility in handhole size allows connections to be made inside the pole, requiring no special connectors or unsightly pull boxes.
- Concrete is more prone to fading than Powder Coated Aluminum Poles.
- Concrete has no recycle value.



The Aluminum Advantage

The ADVANTAGES of Hapco Aluminum poles versus Steel are easily seen.

When communities and project owners specify Hapco Aluminum Poles, they are making an investment in the FUTURE!

The corrosion resistant properties of aluminum and near-zero maintenance lead to inherently longer life cycles, ensuring superior aesthetics for future generations.

ALUMINUM

Aluminum vs. Steel

- Steel is not corrosion resistant and will begin to deteriorate as soon as it is installed.
- Rust creates adhesion issues, leading to poor aesthetics and higher painting maintenance costs. Visible rust and corrosion are common.
- Structural deterioration will result, creating structural integrity issues.
- Limited recycle value.
(Approximately .10¢ versus .96¢ per pound for aluminum.)



Galvanization of Steel

- The Galvanization process is harsh to the environment, emitting both zinc chloride and ammonium chloride.
- The coating produced from the Galvanization of Steel can be easily damaged during handling and installation, allowing immediate oxidation.
- Powder Coat over Galvanizing often result in adhesion issues.



Aluminum production, unlike the galvanization process of steel which emits zinc chloride and ammonium chloride into the atmosphere, has a low impact on the environment, making it especially appealing when both environmental and economic criteria are considered.



Lightweight Aluminum Installations

- Steel poles weigh as much as three times that of aluminum.
- The weight of steel results in longer, more difficult installations requiring larger crews and lifting equipment.
- The heavy weight of steel poles result in increased costs of handling, transportation, and installation.



Yard Handling

Aluminum truckloads are shipped bundled, allowing for less than one hour unloads. Steel truckloads are typically loaded individually, resulting in hours-long unload times.



Save with Direct Buried Aluminum



The use of Hapco Direct Buried Aluminum Poles offer substantial cost savings from the elimination of the foundation.



Direct Buried Aluminum

\$0 Foundation
\$600 Aluminum Pole
\$600

Steel - With Foundation

\$600-\$1,000 Foundation
\$400 Steel Pole
\$1,000 - \$1,400

Net Savings Per Assembly = \$400 - \$800



Shorter Lifecycles

Inherently shorter lifecycles of steel poles lead to guaranteed pole failure and replacement, contributing to both an overall higher cost of ownership and possible liability issues in the event of failure resulting in damage or injury.

Hapco Decorative Pole Products

Hapco has been providing the highest quality Aluminum Decorative Poles to Design Professionals and Landscape Architects for over six decades. From designs that blend with today's modern architectural styles, to historical designs that harken back to an earlier era, Hapco's extensive Decorative Base offering delivers industry-leading design options.



www.HapcoDecorative.com



Structural

Structural Aluminum Bases are welded to the bottom of the smooth or fluted shaft, contributing structural integrity to the pole.



Clamshell

Clamshell Aluminum Bases are 2-Piece designs that are assembled and bolted around the base of the installed pole.

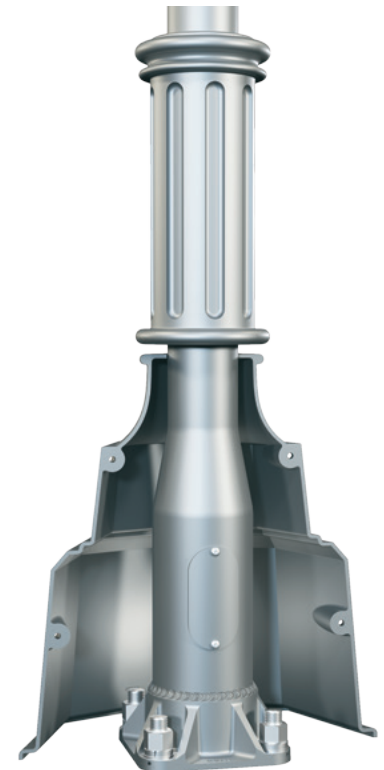

Hybrid Clamshell

Hybrid Clamshell Aluminum Bases provide unique style options by combining a 2-Piece base with other decorative design features.

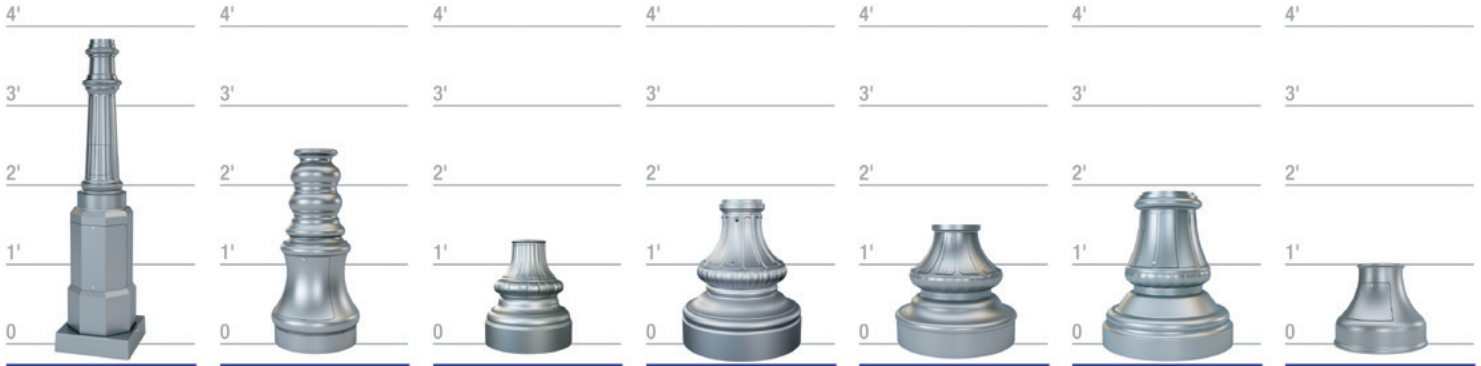

STRUCTURAL Abingdon Base Square: 11.5" 4" Butt Diameter	STRUCTURAL American Base Diameter: 12" 4"-5" Butt Diameters	STRUCTURAL Arlen 13 Base Diameter: 13" 3"- 4" Butt Diameters	STRUCTURAL Arlen 17 Base Diameter: 17" 4"-5"-6" Butt Diameters	STRUCTURAL Arlen 17 Modified Base Diameter: 17" 4"-5"-6" Butt Diameters <i>FHWA Breakaway</i>	STRUCTURAL Arlen 20 Base Diameter: 20" 6"-7"-8" Butt Diameters <i>FHWA Breakaway</i>	STRUCTURAL Bristol Base Diameter: 14.5" 4"-5"-6" Butt Diameters
--	--	---	---	---	--	--

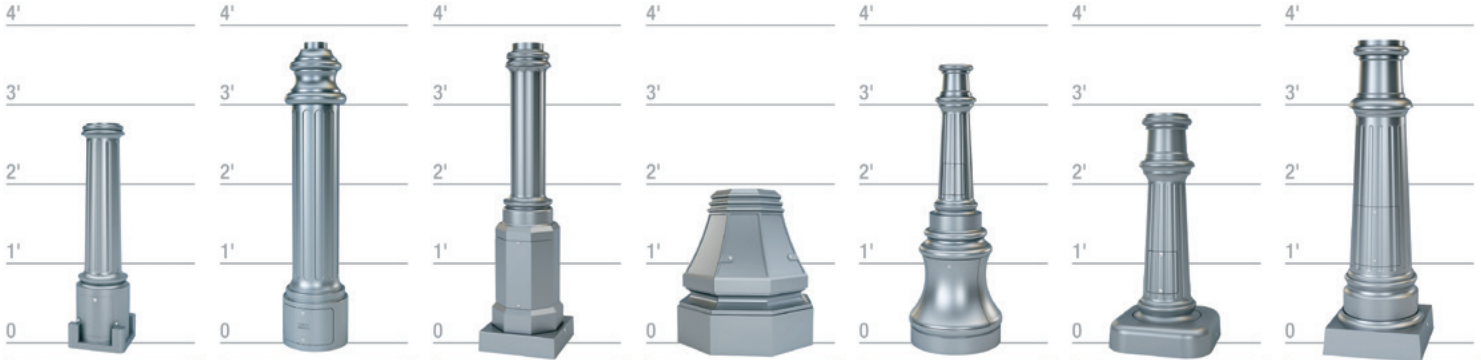

STRUCTURAL Charleston Base Square: 8.5" 4" Butt Diameter	STRUCTURAL Georgetown Base Diameter: 10.125" 4"-5" Butt Diameters <i>FHWA Breakaway</i>	STRUCTURAL Grand Base Square: 11.5" 4"- 5" Butt Diameters <i>FHWA Breakaway</i>	STRUCTURAL Gregory Base Width: 20" 5"-6"-7"-8" Butt Diameters	STRUCTURAL Gunn Base Diameter: 12" 4" Butt Diameter	STRUCTURAL Homewood Base Square: 11.125" 4" Butt Diameter	STRUCTURAL Homewood Large Base Square: 14" 4"-5"-6" Butt Diameters <i>FHWA Accepted</i>
---	---	---	--	--	--	---

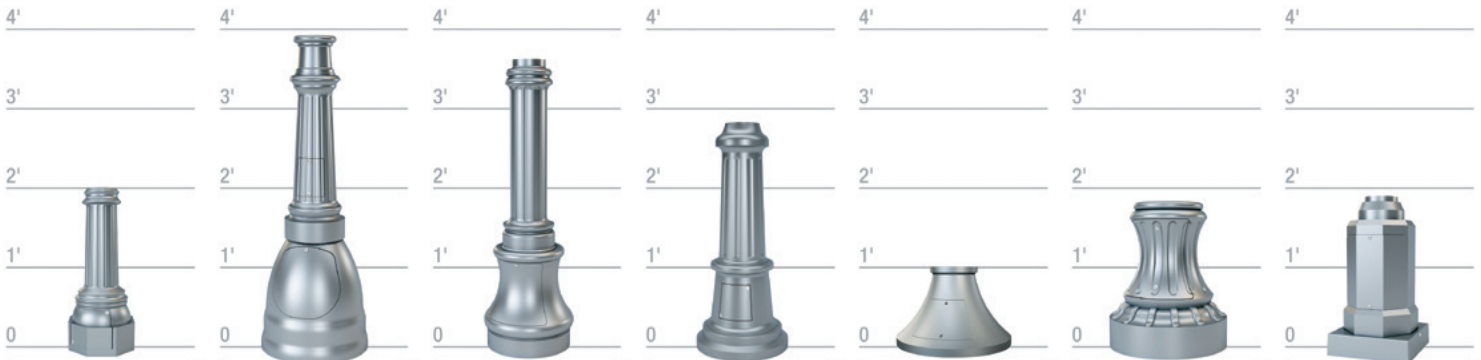

STRUCTURAL Kingston Base Width: 10.75" 4" Butt Diameter	STRUCTURAL Leuin Base Diameter: 13.125" 4" Butt Diameter	STRUCTURAL Lincoln Base Diameter: 12" 4"- 5" Butt Diameters	STRUCTURAL Morgan Base Diameter: 13.5" 4" Butt Diameter	STRUCTURAL Saturn Base Diameter: 20" 5"-6"-7" Butt Diameters	STRUCTURAL Trenton Base Diameter: 16" 4"-5"-6" Butt Diameters	STRUCTURAL Winchester Base Square: 11" 4"-5"-6" Butt Diameters <i>FHWA Breakaway</i>
--	---	--	--	---	--	--

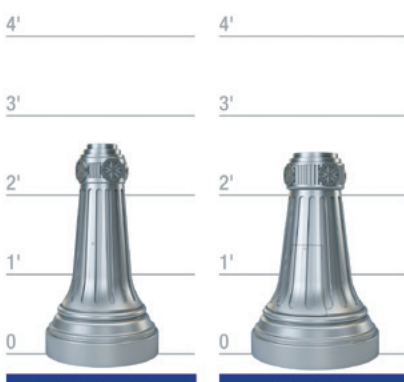

STRUCTURAL York 17 Diameter: 17" 4"-5"-6" Butt Diameters <i>FHWA Breakaway</i>	STRUCTURAL York 20 Diameter: 20" 6"-7"-8" Butt Diameters
--	---

**Direct Buried
Options are
Available in
All Decorative
Bases.**





CLAMSHELL American Base Diameter: 11"-12" 4"-5" Butt Diameters	CLAMSHELL Arlen 17 Base Diameter: 17" 4"-5" Butt Diameters	CLAMSHELL Arlen 20 Base Diameter: 20" 6"-7"-8" Butt Diameters	CLAMSHELL Arlen 24 Base Diameter: 24" 7"-8"-9"-10" Butt Diameters	CLAMSHELL Arlen 30 Base Diameter: 30" 8"-9"-10"-12" Butt Diameters	CLAMSHELL Aubrey Base Width: 26" 5"-6"-7"-8" Butt Diameters	CLAMSHELL Covington Base Diameter: 20" 7"-8"-9"-10" Butt Diameters
---	---	--	--	---	--	---

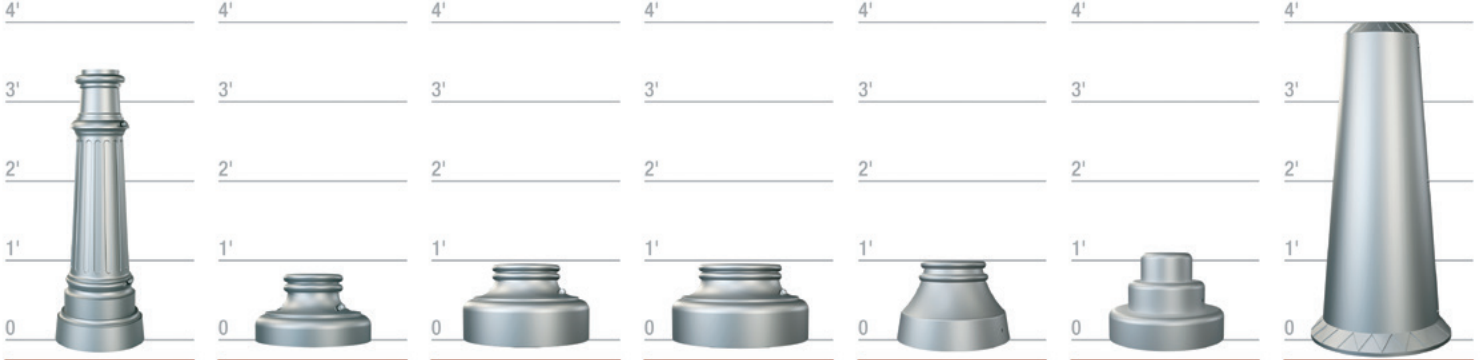

CLAMSHELL Homewood Base Diameter: 14" 4"-5"-6" Butt Diameters	CLAMSHELL Jefferson 15 Base Diameter: 15" 4"-5"-6" Butt Diameters	CLAMSHELL Jefferson 18 Base Diameter: 18" 5"-6"-7"-8" Butt Diameters	CLAMSHELL Jefferson 21 Base Diameter: 21" 9"-10" Butt Diameters	CLAMSHELL Kai Base Diameter: 18" 5"-6"-7"-8" Butt Diameters	CLAMSHELL Mayan Base Diameter: 18" 4"-5" Butt Diameters	CLAMSHELL Nationwide Base Diameter: 22" 7"-8" Butt Diameters
--	--	---	--	--	--	---

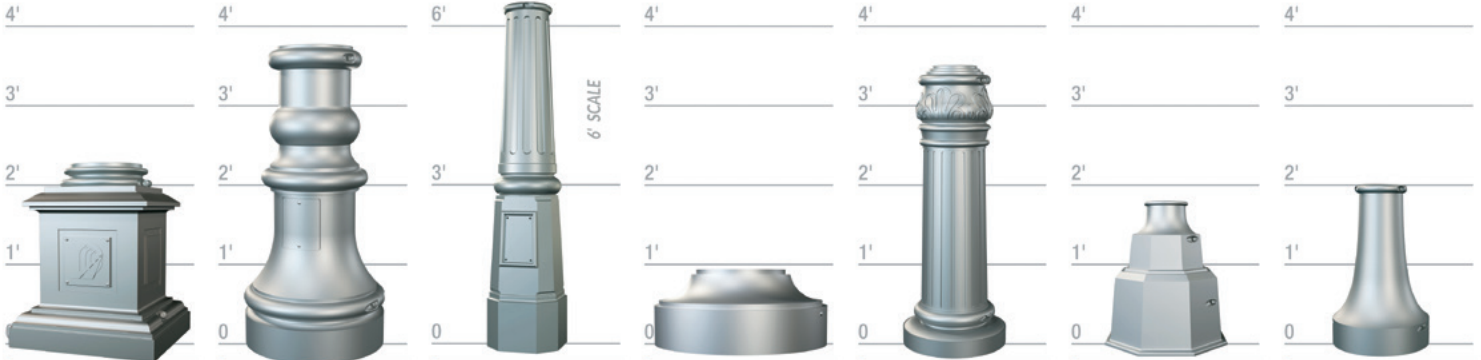

CLAMSHELL Palms Base Square: 22" 6"-7"-8"-9"-10" Butt Diameters	CLAMSHELL Redding Base Diameter: 20" 6"-7"-8"-9" Butt Diameters	CLAMSHELL Regal Base Width: 16" 5"-6"-7"-8" Butt Diameters	CLAMSHELL Rio Base Diameter: 27" 8"-9"-10"-12" Butt Diameters	CLAMSHELL Staunton Base Diameter: 16" 6"-7"-8" Butt Diameters	CLAMSHELL Sterling Base Width: 17" 4"-5" Butt Diameters	CLAMSHELL Yale 15 Base Diameter: 15" 4"-5"-6" Butt Diameters
--	--	---	--	--	--	---

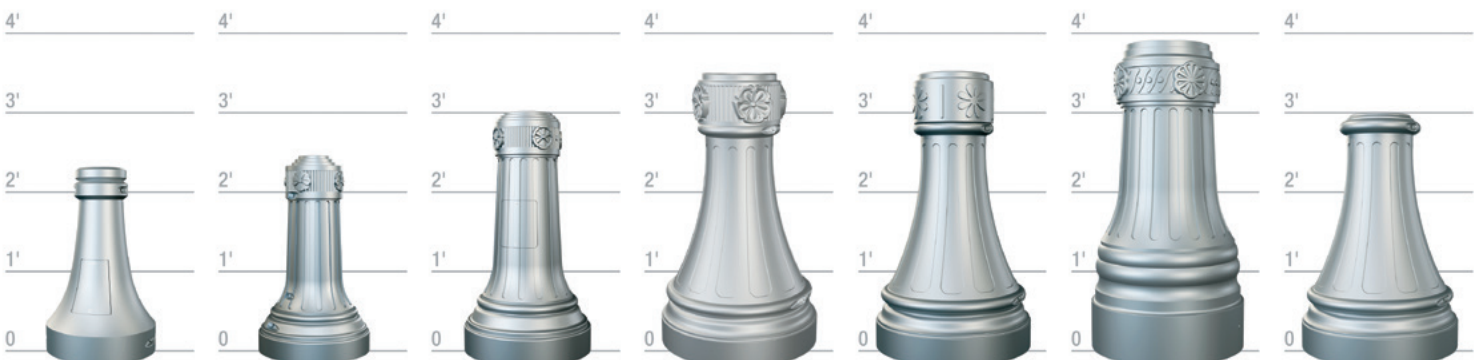

CLAMSHELL Yale 17 Base Diameter: 17" 4"-5"-6" Butt Diameters <i>FHWA Breakaway</i>	CLAMSHELL York 17 Base Diameter: 17" 4"-5"-6" Butt Diameters	CLAMSHELL York 20 Base Diameter: 20" 6"-7"-8" Butt Diameters	CLAMSHELL York 24 Base Diameter: 24" 6"-7"-8"-9" Butt Diameters	CLAMSHELL York 24 Floral Base Diameter: 24" 6"-7"-8"-9" Butt Diameters	CLAMSHELL York 24 Modified Base Diameter: 24" 8"-9"-10"-12" Butt Diameters	CLAMSHELL York 24 Non-Floral Base Diameter: 24" 7"-8"-9" Butt Diameters
--	---	---	--	---	---	--

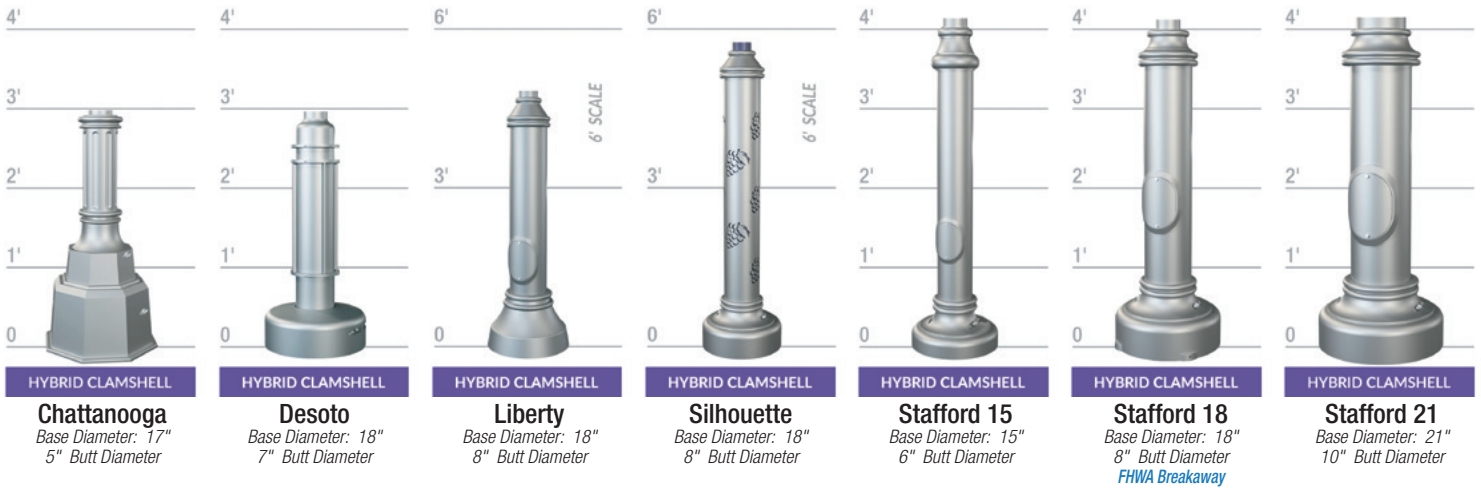

www.HapcoDecorative.com

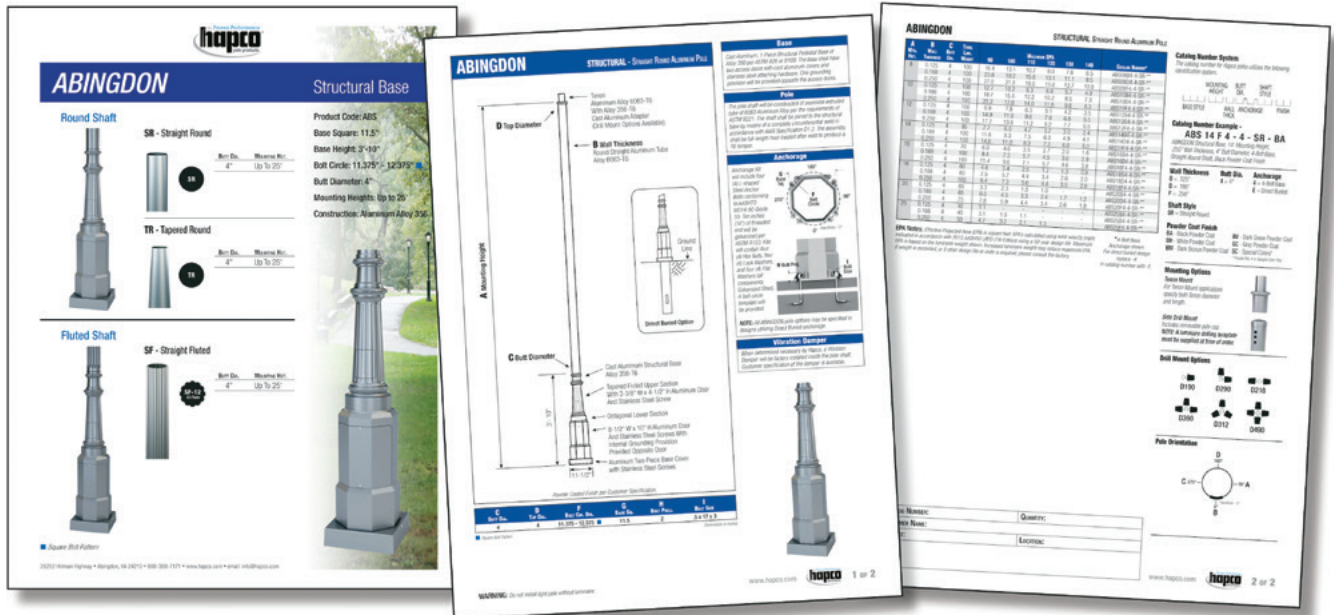

58 PDF Catalog Pages.

386 Specification Sheets.

6,954 Standard Product Combinations.

Base Details, Pole Shaft Details, and EPA Tables for Straight Round, Tapered Round, Straight Fluted, and Tapered Fluted Options.

HAPCO Leads the Industry in Federal Highway Administration (FHWA) Accepted Breakaway Options.

The Federal Highway Administration (FHWA) definition of “Breakaway” refers to crash-tested devices that break or yield upon impact. FHWA guidelines require the specification of Breakaway poles and bases meeting rigorous impact testing to mitigate the potential severity of crashes, providing a safer outcome in the event of a collision.



The FHWA accepts certain poles and bases for use on breakaway applications under provisions adopted from the American Association of State and Highway Transportation Officials’ (AASHTO) *Standard Specifications for Structural Supports for Highway Signs, Luminaires and Traffic Signals*. Testing parameters used in determining acceptable breakaway performance are found in the National Cooperative Highway Research Program (NCHRP) Report 350, *Recommended Procedures for the Safety Performance Evaluation of Highway Features*.



4-Bolt Breakaway Anchor Base

Hapco’s Anchor Base was the first pole anchoring shoe base allowing standard installation techniques to meet FHWA Breakaway provisions. Its simplicity of design eases the installation process, combining the most cost efficient Breakaway device in the industry with the aesthetic appeal of a standard shoe base.

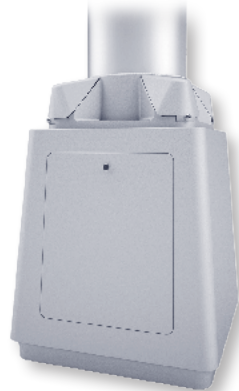

Breakaway T-Base

Hapco offers Transformer Base (*T-Base*) designs to accommodate a wide range of pole sizes and bolt circle requirements. The historic appearance of the T-Base design offers a higher probability of re-use of the pole in the event of a knockdown.

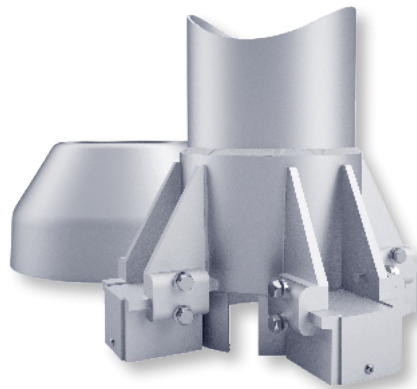

X-Base

The X-Base, a Hapco exclusive, is welded to the bottom of the base as part of the pole assembly. It is supplied assembled and serves as the base flange, bolting directly to the anchor bolts. The X-Base extends the range of sizes for FHWA accepted Breakaway poles to a 10” Butt Diameter and 55’ Mounting Heights.

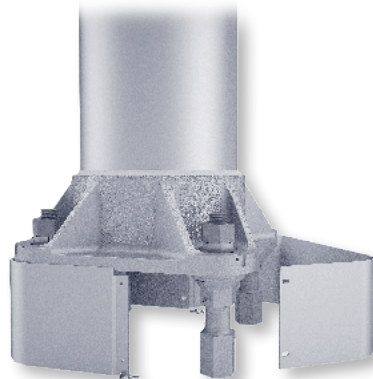

Breakaway Couplings

Breakaway couplings are available for use in a wide range of pole sizes.



Screen captures of high speed video of Hapco's Direct Buried FHWA Accepted Breakaway Aluminum Pole.

Hapco is proud to offer the industry's first FHWA Accepted Direct Buried Breakaway Aluminum Pole.

Aluminum poles used in direct buried applications throughout the country have a 60 year record of successful installations and can provide significant overall job savings.

Through an extensive process of expert design, modeling, and testing, Hapco engineers have created a breakaway design that brings the cost efficient properties of direct buried poles to our FHWA accepted Breakaway product line.

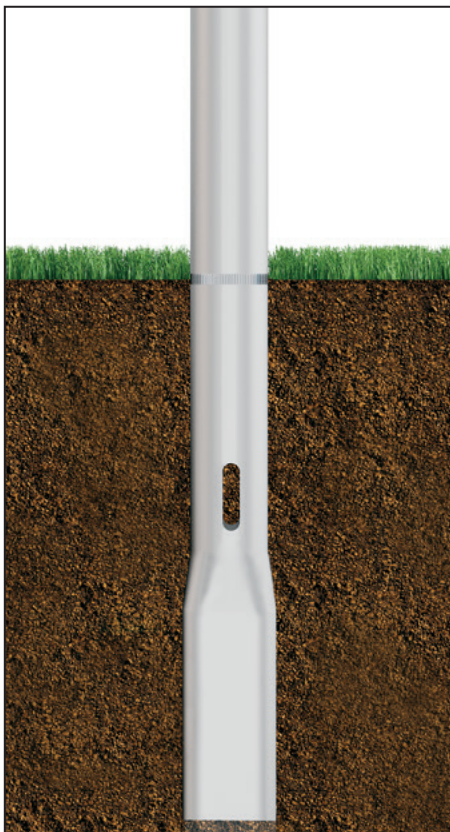

The butt end of Hapco Direct Buried Breakaway poles are partially flattened into an oval cross section, providing an anti-rotational device.

Direct Buried Advantages

- Provides faster, more cost efficient pole installations.
- Eliminates foundations, removing the associated costs and the possibility of improper pouring/setting.
- Eliminates the need for bolt circle templates and anchor bolts.
- Eliminates the use of shims or double nuts for leveling.
- Eliminates improper bolt projections that result in uneven base covers and grouting.
- Eliminates the possibility of foundation and anchor bolt replacement in the event of a knockdown.
- Reduces the risk of wind induced vibration due to the ground acting as a natural damper.
- Provides more strength, lending greater EPA values than anchor base designs due to the elimination of the weld joint.
- Improves Aesthetics.



Extensively Tested
FHWA Accepted
Exclusive Lifetime Warranty



Decorative Breakaway Solutions

Hapco leads the industry in Decorative Breakaway options. From designs that blend with today's modern architectural styles, to historical designs that harken back to an earlier era, this collection of FHWA accepted Decorative Breakaway bases is sure to offer the solution for your streetscape vision.

All Options Shown are FHWA Accepted.



Arlen 17 Modified



Arlen 20



Georgetown
Also Available
DIRECT BURIED



Grand
Also Available
DIRECT BURIED



Homewood Large



Winchester
Also Available
DIRECT BURIED



York 17
ONLY Available
DIRECT BURIED



2-Piece
Clamshell
Design

Yale 17



2-Piece
Clamshell
Design

Stafford 18

FHWA Accepted Breakaway Streetscape Solutions

Hapco's FHWA accepted Breakaway Structural Bases offer the perfect solution to your next streetscape project. These options allow design professionals the ability to incorporate a coordinating look in both ROADWAY STREET and PED SCALE lighting.

Arlen 20" Structural
*FHWA Accepted -
Roadway Street Breakaway*



Arlen 17" Modified
*FHWA Accepted -
PED Scale Breakaway*

Roadway

Arlen 20" Structural
*FHWA Accepted -
Breakaway*



Up to 35'
*Round Tapered
Mounting Height*

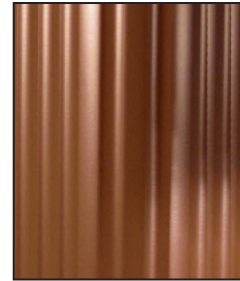

Up to 30'
*Round Tapered
16 Flute
Mounting Height*

Maximum mounting height based upon EPA calculations per AASHTO 2001's most stringent South Florida requirement (146 MPH zone and 50 year design life).



Eliminate couplings.

The use of Hapco's FHWA accepted Breakaway options eliminates the need to use couplings, producing both cost-savings and superior aesthetics.

PED Scale

Arlen 17" Modified
*FHWA Accepted -
Breakaway*



SMARTTRAC™

Smart Pole Solutions

Poles Your City's Future Can Rely On

ADAPTABLE • FUTURE-PROOF • LIFETIME WARRANTY

SMART TRAC, Hapco's patent-pending aluminum POLE SYSTEM, offers innovative multi-use poles and accessory mounting options that are the perfect blend of functionality, versatility, strength and aesthetics.

Four Shaft Sizes

SMART TRAC shafts are offered in 4", 6", 8" and 12" Butt Diameters. Each shaft is designed with four identical "TRAC" systems at 0°, 90°, 180°, and 270°. This allows all accessory attaching hardware to work with all SMART TRAC designs.

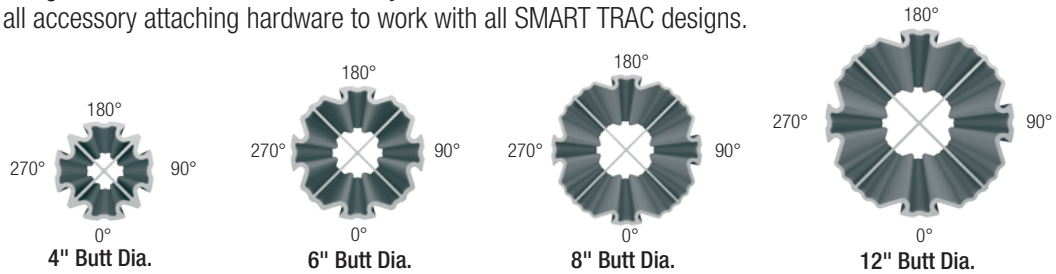

Multiple Design Configurations

SMART TRAC offers cities a broad range of design possibilities. Choices include 4", 6", 8" and 12" diameter STRAIGHT designs, along with 6" transitioning to 4", 8" transitioning to 6", and 8" to 6" to 4".

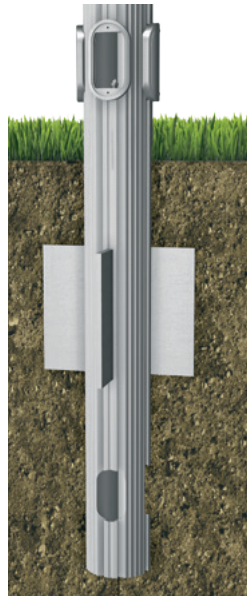

Direct Buried Options

Direct Buried (*Embed*) SMART TRAC options are available in all sizes and mounting heights, allowing for faster, more cost-efficient installations.



Signal Isolation Solution
SMART TRAC is the PERFECT Signal Isolation Solution for Multi-Use poles utilized by today's Smart Cities.

Locking Cam

The Patent-Pending design of SMART TRAC allows the use of a Locking Cam for the mounting of a variety of pole accessories. When tightened against the pole, the grooves of the Locking Cam twist, pull, and tighten against the tracs of the pole. Strong, secure, and simple installations that can be moved, modified, or removed and replaced without the unsightly bands and drill holes associated with standard pole accessories.



Heavy-Duty Arm Mounting Bracket



SMART TRAC's Heavy-Duty Bracket is designed for use with the most common arm designs and can be used in combinations for Truss Arms and Custom Designs. NO DRILLING of the pole is required, allowing jobsite placement and future movement.

SMART TRAC is the FOUNDATION for tomorrow's Smart Cities.

Multi-Chamber Aluminum Poles

A Smart Pole Solution For Today's Smart City

Hapco's multi-chamber aluminum poles are the perfect **Signal Isolation Solution** for the growing complexity of communications and control systems.

Poles used in today's Smart Cities function as more than a support for the lighting fixture. Multi-use attachment requirements continue to grow, with options including security, sensors, cameras and 5G broadband with its associated antennas, radios, wireless relays, meters, and power disconnects.



- **Eliminate the Possibility of Signal Interference.**
Allows the use of multiple power sources.
- **Separate Access to Each Chamber.**
Security for each individual provider.
- **Adaptable and Future-Proof.**
Ready for future expansions and technologies.
- **Internal Web Design Improves Loading Capacities.**
Increased Loading for Whatever the Future May Hold.
- **LIFETIME Pole Shaft Warranty**



Dual-Chamber
Mounting Heights:
Up To 45'
Butt Diameters:
6" and 10"



Tri-Chamber
Mounting Heights:
Up To 45'
Butt Diameters:
6" and 10"



Tri-Chamber Fluted
Mounting Heights:
Up To 50'
Butt Diameters:
8" and 10"



Dual-Chamber Square
Mounting Heights:
Up To 30'
Butt Square: 6"

Transition Adapters Dual and Tri-Chamber - Round

Hapco's patented (Patent #10302289) Multi-Chamber Transition Adapters are available in both Dual and Tri-Chamber Smart Pole options. These pole designs combine the aesthetics of a 10" Butt Diameter transitioning into a 6" Diameter upper shaft with continuous signal isolation.

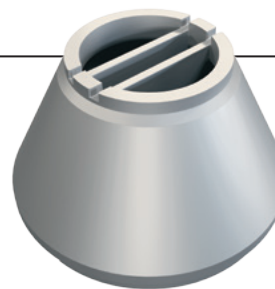
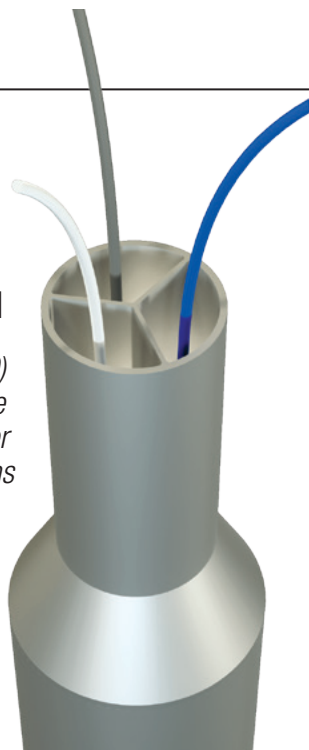

**Dual-Chamber
Transition Adapter**

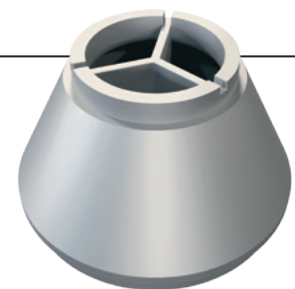

**Tri-Chamber
Transition Adapter**



Oversized Handholes

Make your electrical wiring connections inside the pole. Achieve cost savings by specifying Hapco's oversized handholes!

- X Eliminate the cost of the Junction Box.**
- X Eliminate the cost of Box installation.**
- X Eliminate the cost of Submersible Connectors.**



Avoid electrical shortage hazards due to in-ground moisture.



Locking Handhole Cover

An Effective Deterrence Against Copper Theft

Hapco's heavy-duty, Locking Handhole Cover creates secure access to pole wiring while maintaining a sleek and aesthetic look.

- **Simple Installation**
- **Easy, Keyed Access to Authorized Users**
- **No Lost Covers or High Maintenance Costs Associated With Copper Theft**
- **Increased Safety Reduces Liability**



Available in 4" x 6" and Larger Handholes.

Universal Bolt Circle Adapter

The Hapco Universal Bolt Circle Adapter offers a unique solution to using existing anchorage with new and varying bolt circle requirements. In addition to being versatile, the Bolt Circle Adapter eliminates both the cost of removing an existing foundation and the cost of new anchor bolts and new foundation.

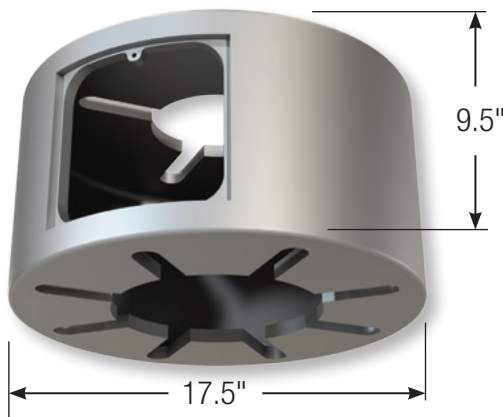
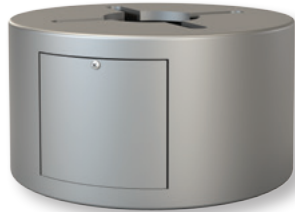

Top Bolt Circle	7.5" - 12"
Bottom Bolt Circle Range - Diamond	10.5" - 14"
Bottom Bolt Circle Range - Square	10.5" - 14.5"

Hapco's team of Engineers stand ready with the technical competence and experience to assist on your project. Please contact Hapco for base compatibility and loading/design assistance.

Streetscape Solution

Hapco provides urban designers with Decorative options to further streetscape beautification. Coordinated project designs incorporating Roadway and Pedestrian lighting poles with matching Traffic and Roadway Signage are available.



Custom Poles and Bases

No one can duplicate Hapco's ability to deliver solutions to design professionals and project owners looking for that truly custom or unique design. Long recognized as the leader in providing innovative light poles and brackets, our team of engineers stand ready with the technical competence and experience to assist on even the most complex project.



"Expert Engineering design, world-class Manufacturing capabilities, and an emphasis on Quality Control make Hapco the PERFECT choice for your next custom project."



Lifetime Quality...Guaranteed

At Hapco, it is our mission to create lasting customer relationships by providing the very best quality products. We do this by combining the most advanced, industry-leading manufacturing technologies with exceptional engineering and design.

Because we stand behind our products and truly believe in their longevity and durability, our aluminum pole assemblies are covered by a Lifetime Warranty.



"As a leader in the manufacture of aluminum lighting poles for more than 60 years, we are proud to be the first in the metal pole industry to offer this guarantee. We have the facilities, the products, the people, the experience and the desire to become and stay your FIRST choice for aluminum pole lighting solutions."

Lifetime Warranty

Hapco warrants its aluminum pole assemblies for their lifetime to be free of defects in material and workmanship and to be free from corrosion, except those items normally consumed in service. This warranty does not cover failures or corrosion due to:

- Improper installation.
- Misapplication – product used outside of specified use.
- Damage from handling, transportation, installation, vehicular impact, abuse, or vandalism.
- Site specific wind induced or other vibration.
- Installation in soils with a pH under 5 or over 9.
- Improper grounding.

Hapco will, at its sole option, repair, replace, or credit Buyer's account for any product that does not conform to this warranty.

HAPCO MAKES NO OTHER WARRANTIES, EXPRESS OR IMPLIED, INCLUDING THE IMPLIED WARRANTIES OF MERCHANTABILITY OR FITNESS FOR A PARTICULAR PURPOSE. HAPCO SHALL NOT BE LIABLE FOR ANY OTHER LOSS OR DAMAGE, INCLUDING BUT NOT LIMITED TO CONSEQUENTIAL DAMAGES, LIQUIDATED DAMAGES AND BACK CHARGES.

This warranty does not include reimbursement for the expense of installation or removal of equipment, transportation, or any other expenses which may be incurred. This warranty applies to the pole assembly only and does not include anchor bolts, connecting hardware, or foundation. Authorization must be obtained from Hapco before any material is returned. This warranty excludes finishes such as powder coating, anodizing, and satin. "Lifetime" is defined as the lifetime of the products intended use. The foregoing states the Buyer's sole remedy for any breach of warranty by Hapco.

This warranty applies only to Hapco aluminum pole assemblies shipped on or after January 1st, 2011.

Hapco
26252 Hillman Highway
Abingdon, VA 24210
Toll Free: 800-368-7171
www.hapco.com





***Hapco Aluminum, a sustainable material
for now and the future!***

Hapco Aluminum - The Green Choice

Hapco Aluminum Poles provide an environmentally responsible choice of material and approach with the burgeoning green movement, allowing specifiers to aggressively pursue a design based upon sustainable principles.

Aluminum resists the ravages of time, temperature, corrosion, humidity, and warping, creating an incredibly long life cycle when compared to alternative materials. This results in a far lower environmental impact through reduced material replacement energy.

The longevity and durability of aluminum pole products manufactured by Hapco can be validated by our industry-leading **Lifetime Warranty on Aluminum Pole Assemblies**, making Hapco Aluminum **"The Green Choice"** for today's environmentally-conscience designer.

- *Aluminum is 100% recyclable. In fact, 70% of aluminum produced since the year 1886 is still in use today.*
- *Recycling aluminum saves 95% of the energy it would take to produce new material from Bauxite Ore.*
- *Every ton of recycled aluminum saves 4 tons of the raw Bauxite required to produce new aluminum.*
- *Using recycled aluminum, instead of raw materials, reduces air pollution by 95% and water consumption by 97%.*
- *Aluminum is naturally corrosion-resistant, eliminating the use of toxic chemicals to maintain its appearance.*
- *Aluminum recycling benefits present and future generations by conserving energy and other natural resources.*





HAPCO

26252 Hillman Highway
Abingdon, VA 24210
800-368-7171
email: info@hapco.com
web: www.hapco.com

H-502 (05-20) ©2020 HAPCO



Proudly Supporting Our Industry...

American Welding Society
AWS D1.2 Committee

*American Association of State Highway
and Transportation Officials*
AASHTO NCHRP

National Electrical Manufacturers Society
NEMA ANSI C136

Accredited Standards Committee

